



GREEN COAL TO LIQUIDS PROJECT TECHNICAL AND ECONOMIC FEASIBILITY

STUDY AREA:
MAXCOAL LUDEWA,
MASIMABARAFU
VILLAGE, LUDEWA
DISTRICT, NJOMBE,
TANZANIA

MAJOR PRODUCTS:
DIESEL AND PETROL
FROM COAL



APRIL 2022

Developer

Maximum Energy and Mineral Limited Company

P.O.BOX 70405, Dar Es Salaam

Mobile : +255 785 281 481

Email : maximumenergyandminerals@gmail.com

www.maximumcompanies.com

Consultants

Energy Thinktank Africa (ETTA) Limited

ESBC Office Complex 1st Floor, Kimbiji House, 344 Ghuba
Road

Oysterbay Shopping Centre, Dar es Salaam, Tanzania.

Tel: +255 222 96000

Disclaimer

This feasibility report (including any enclosures and attachments) has been prepared for the exclusive use and benefit of Maximum Energy and Minerals Limited (MEML) and Energy Thinktank Africa (ETTA) and solely for the purpose for which it is provided. Unless provided through a written consent, no part of this report should be reproduced, distributed, or communicated to any third party. Energy Think Tank Africa (ETTA) Limited does not accept any liability if this report is used for an alternative purpose from which it is intended, nor to any third party in respect of this report.

Executive Summary

Overview

This report presents an analysis for technical and economic feasibility of a commercial coal-to-liquids (CTL) facility in Ludewa producing about 20,000 barrels of liquids fuels per day. This facility uses gasification and Fischer-Tropsch technology to convert about 11,000 tonnes per day of Maxcoal Ludewa's bituminous coal to commercial-grade diesel and gasoline. In addition, the facility is expected to generate a net power of approximately 50MW_e that can be exported to the national grid. Other by-products of value include elemental sulphur and tar. The design of this facility ensures zero CO₂ emission through capture, compression, transport, and storage.

Process Design

The plant is designed with a goal gasification system and a F-T reactor system that uses iron-based catalyst. This feasibility study was done on a plant concept that includes a combination of two gasification plants, each containing two gasifier trains summing up to a total of four gasifier trains. The clean syngas from the gasifiers is collected and sent to a central plant. This central plant consists of the F-T reactor cycle, hydrotreating and hydrocracking units that nominally produce about 12,000 bbl/day of commercial-grade diesel and 8,000 bbl/day of gasoline. The CTL plant also generates a net electric power of approximately 50 MW_e from heat recovery steam generators that collect waste heat from gasifiers and F-T reactors, and gas turbine generators that burn tail gas.

The syngas from gasifier is stripped of H₂S and CO₂ by a Selexol absorption system to be cleaned. Sulphur is recovered from H₂S in a Claus plant and is included as a saleable product in this analysis. The plant design includes equipment for

compressing the captured CO₂ to 150 barg pressure for pipeline injection. The CO₂ compression facility is included for subsequent CO₂ capture that is not included in this design. Table 1 presents a summary of the performance data of the CTL facility.

Table 1: Plant performance summary

Parameter	Value
Liquids (bbl/day):	
Gasoline	8,000
Diesel	12,000
Total Liquids	20,000
Net plant power (MW _e)	50
Coal Feed (tonnes/day)	11,000
Sulfur production (tonnes/day)	87.5
CO ₂ captured (tonnes/day)	16,859

Market Analysis

The expected production from the planned CTL plant is 20,000 bbl/day which is about 34% of the total daily consumption of diesel and gasoline in Tanzania. Currently, Tanzania depends 100% on fuel import. This results in unpredictable pump prices as it largely depends on crude oil price which is affected by global trends. The fuel produced from the planned CTL plant will be sold at affordable and predictable prices since it is not impacted by global changes. This gives Maximum Energy and Minerals Ltd a competitive market position.

Moreover, 87tonnes/day of Sulphur, 50MW_e and 1,759 tonnes/day of tar/slag will be produced from the operations. The primary market of Sulphur is planned for export to China, India, or Turkey while the secondary market is planned for domestic use to be sold to agrochemical manufacturing companies in Tanzania.

The electricity can be sold locally in Tanzania or sold to Malawi, the neighboring country. As for the tar, due to its high quantity, Maximum Energy and Minerals Ltd can promote it as a building material in residential homes for example as an alternative to pavement blocks. Various promotion and awareness creation programs are needed to facilitate this novel adoption.

Financial Analysis

The total EPC cost estimate is \$1,479,199,000. Adding the cost of purchase of vehicles, loan insurance and the loan interest for the first four years before operation commences brings the total investment cost to \$1,693,313,255. Operations and maintenance cost values were determined on a first-year basis and then applied over the 30-year plant life. First-year operations and maintenance (O&M) estimates are \$90.1 million for fixed O&M and \$282.4 million for variable O&M.

For the financial analysis assumptions applied include: 30% income tax rate, a 30-year plant life, 100% plant availability, 4% project and process contingency, 13% discount rate, 6 years pay-back period, 85:15 debt to equity ratio for the EPC cost, 4% loan interest and 10-year loan repayment period. The prices for fuel \$100 per bbl, electricity and Sulphur. The results showed a ROI of 30%, NPV of \$513,155 and the break-even price of \$45.35.

A sensitivity analysis to identify the parameters with the greatest impact on ROI and NPV, using a $\pm 25\%$ change in the input value for project plant, storage farms and fleet costs, income tax rate, project life, interest rate and depreciation. Results showed the income tax rate and the plant, storage farms and fleet costs were the most sensitive inputs. But overall, the sensitivity analysis showed robust financial projections with lowest ROI of 14% and highest 47% for a $\pm 25\%$ change.

Remarks

The planned CTL plant will serve the country's energy security issues and reduce dependence on importation of liquid fuels, in this setting and considering Tanzania's fuel market, the plant is strongly profitable. Utilization of modern and advanced technologies, the motive of the owners and planned environmental impact mitigation measures makes the plant environmentally friendly. We would like to highly recommend implementation of this project.

Acknowledgments

1. **Eng. Zawadi Ntengua Mdoe**, BSc. Hons. Chemical and Process Engineering UDSM, MSc. Chemical Engineering, PhD Chemical Engineering, NTNU Ongoing. Email: zawadi.n.mdoe@ntnu.no
2. **Eng. Bertha Joseph Ngereja**, BSc. Hons. Industrial Engineering and Management, UDSM, MSc. Project Management, PhD Project Management, NTNU ongoing. Ex SCHLUMBERGER SEACO.INC Senior Field Engineer. Email: bertha.j.ngereja@ntnu.no
3. **Prof. Richard Rwechungura**, BSc. Hons. Chemical and Process Engineering UDSM, MSc. Petroleum Engineering & PhD Petroleum Engineering NTNU. Associate Professor Norwegian University of Science and Technology – NTNU. Email: Richard.rwechungura@ntnu.no
4. **Eng. Immaculate Francis Tsere**, Operations Manager, Maximum Energy and Minerals Limited. Email: immaculate.maximumenergy@gmail.com
5. **Eng. Masolwa Kasongi Enos**, Principal Consultant, Energy Systems, Energy Thinktank Africa (ETTA) Limited. Email: masolwaenos@gmail.com
6. **Mr. Mustapha Njozi**, Principal Consultant, Project Management and Control, Energy Thinktank Africa (ETTA) Limited. Email: mjnjozi@gmail.com
7. **Ligniko Chale**, Chairman, Maximum Group of Companies, Maximum Energy and Minerals Limited (MEML) Email: maximumenergyandminerals@gmail.com
8. **Godfrey Kishe**, Director, Maximum Group of Companies, Maximum Energy and Minerals Limited (MEML) Email: gjkishe@gmail.com

About Maximum Energy and Minerals Company Limited

Established in the year 2014, “Maximum Group” is an ambitious epitome of smartness and sustainability in Tanzania with planned major investments and companies in key business sectors. The Group is in areas as diverse as Trading, Agriculture, Manufacturing, Energy and minerals, Pharmaceuticals and Real estate.

The Company was founded by Chairman, Mr. Liginiko Musa Chale and registered in the United Republic of Tanzania.

Maximum group of companies comprises of:

- 1. Maximum Energy and Minerals Limited (MEML)**
2. Maximum Agro Resources Limited (MARL)
3. Maximum Healthcare Limited (MHCL)
4. Maximum Housing Limited (MHL)

Maximum Energy and Minerals Limited (MEML) owns 54 km² of coal mine in Masimabarafu village, Ludewa district, Njombe region in Tanzania. The company is currently producing 50,000 tonnes per month of coal selling domestically in local cement factories. Maximum Energy is working on a value addition of its coal by sustainably producing liquid fuels from its abundant coal.

About Energy Thinktank Africa (ETTA) Limited

With headquarters in Dar es Salaam, Energy Thinktank Africa (ETTA) Limited is a consulting company with a vision of being an enabler of Sustainable Energy for Development in Africa (SE4D). Through the utilization of renowned professionals and experts across the globe, ETTA supports and connects stakeholders to opportunities. ETTA deals with all forms of energy including but not limited to Geothermal, Wind, Solar, Hydropower, Clean Coal Technologies and Oil and Gas. It provides valuable and constructive solutions to Energy related Ideas, Research, Innovation at various phases of projects including feasibility studies, project planning, front end engineering and design (FEED) and management and control. ETTA was given mandate to conduct feasibility study on behalf of Maximum Energy and Minerals Limited for the planned attractive coal to liquids plant.

Table of Contents

DISCLAIMER	II
EXECUTIVE SUMMARY	III
OVERVIEW	III
PROCESS DESIGN.....	III
MARKET ANALYSIS	IV
FINANCIAL ANALYSIS.....	V
REMARKS	VI
ACKNOWLEDGMENTS.....	VII
ABOUT MAXIMUM ENERGY AND MINERALS COMPANY LIMITED	VIII
ABOUT ENERGY THINKTANK AFRICA (ETTA) LIMITED	IX
LIST OF FIGURES	XIII
LIST OF TABLES	XIV
APPENDICES.....	XV
LIST OF ABBREVIATIONS AND UNITS	XVI
1. INTRODUCTION.....	1
2. TECHNOLOGY CONSIDERATION.....	5
2.1 RESERVE ESTIMATE.....	5
2.2 CLEAN COAL TECHNOLOGIES AND ENVIRONMENT.....	7
2.2.1 <i>Plant Inputs</i>	9
2.2.2 <i>Plant Outputs</i>	9
2.2.3 <i>CO₂ and CCS</i>	9
2.2.4 <i>Global CCS Overview</i>	11
2.2.5 <i>CTL Energy Transition Plan</i>	12
2.3 ENVIRONMENTAL IMPACTS AND MITIGATION	13

x

GCTL PROJECT Feasibility Report

2.4	PLANT DESIGN BASIS	15
2.4.1	<i>Site Description</i>	15
2.4.2	<i>Design Fuel Characteristics</i>	16
2.4.3	<i>Environmental Requirements</i>	16
2.5	PLANT ANALYSIS	17
2.5.1	<i>Assumptions for Plant Analysis</i>	17
2.5.2	<i>Analysis of Plant Concept</i>	18
2.5.3	<i>Process Description</i>	19
2.6	PLANT DESIGN.....	23
2.6.1	<i>Description</i>	23
2.6.2	<i>General Description of the Process Systems</i>	26
2.6.3	<i>Major Equipment List</i>	36
2.6.4	<i>Capital Costs</i>	36
2.6.5	<i>Operating and Maintenance Costs</i>	36
3.	MARKET ANALYSIS	39
3.1	PRODUCT MARKETPLACE	39
3.1.1	<i>Fuel Marketplace in Tanzania</i>	39
3.1.2	<i>Fuel Pricing in Tanzania</i>	41
3.1.3	<i>Sulphur Marketplace in Tanzania</i>	44
3.1.4	<i>Sulphur Prices in Tanzania</i>	46
3.2	MARKETING STRATEGY.....	46
3.2.1	<i>Pricing Strategy</i>	47
3.2.2	<i>Location</i>	48
3.2.3	<i>Promotion</i>	48
3.2.4	<i>People</i>	48
3.2.5	<i>Physical Facilities</i>	49
3.2.6	<i>Process</i>	49
4.	ORGANIZATION/STAFFING.....	51

GCTL PROJECT Feasibility Report

5.	SCHEDULE	53
6.	FINANCIAL PROJECTIONS.....	54
6.1	FINANCIAL ANALYSIS.....	54
6.2	PERFORMANCE AND COST SENSITIVITIES.....	56
6.3	PROJECTED INCOME STATEMENT.....	59
6.4	STATEMENT OF CASH FLOW	61
6.5	BALANCE SHEET	62
7.	FINDINGS AND RECOMMENDATIONS.....	63
7.1	TECHNOLOGY	63
7.2	MARKETING.....	63
7.3	ORGANIZATION.....	64
7.4	FINANCIAL	65
7.5	RECOMMENDATIONS	65
	NOTES 1	89
	NOTES 2	90
	NOTES 3	91

List of Figures

Figure 1: Recoverable Reserves Estimation (David Coil; Erin McKittrick; Bretwood Higman, 2012).....	7
Figure 2: Clean Coal Technologies	8
Figure 3: Geological CO ₂ storage methods (IPCC, 2005).....	10
Figure 4: CO ₂ volume change with depth	11
Figure 5: CO ₂ – Enhanced Coal Bed Methane Production concept	13
Figure 6: Overall process configuration	23
Figure 7: Plant design concept with two gasification clusters.....	24
Figure 8: The total number of petrol stations in Tanzania between 2018 and 2020	40
Figure 9: Crude oil price from 2017 to 2020	43
Figure 10: Average pump prices per litre for gasoline and diesel from 2017 to 2020	43
Figure 11: Expected distribution between gasoline and diesel imports and the planned CTL Plant	44
Figure 12: Average Sulphur prices in Tanzania	46
Figure 13: Summary of the marketing strategy	50
Figure 14: Maximum Group of Companies organization structure	51
Figure 15: Estimated CTL Plant Project timeline.....	53
Figure 16: Major Inputs and outputs of Green Coal to Liquid Plant project with nominal 20,000 bbl/day	54
Figure 17: Changes in ROI with +/-25% change in selected inputs.....	57
Figure 18: Changes in NPV with +/-25% change in selected inputs.....	59

List of Tables

Table 1: Plant performance summary	iv
Table 2: Ludewa Coal Seam Resources	5
Table 3: Summary Environmental Impacts and Suggested Mitigation Measures ...	14
Table 4: Generic site ambient conditions	15
Table 5: Generic site characteristics	15
Table 6: Ludewa design coal	16
Table 7: Consumable chemicals cost	37
<i>Table 8: Summary of Total Plant Cost</i>	38
Table 9: Gasoline and Diesel consumption overview	39
Table 10: An overview of gasoline and diesel importation for 2019 and 2020	41
Table 11: Expected marketplace of the Green CTL plant products	47
Table 12: Operating labour requirements for the project.....	52
Table 13: Financial Analysis Results	56
Table 14: Values used in sensitivity analysis (in thousand dollars)	57
Table 15: Projected Income Statement for Year 1.....	60
Table 16: Statement of cash flow for Year 1.....	61
Table 17: Balance sheet for Year 1.....	62

Appendices

Appendix i: Proximate, GCV and Ultimate Analysis of Coal Sample	68
Appendix ii: Analytical Report 1.....	69
Appendix iii: Analytical Report 2.....	72
Appendix iv: Prospecting License.....	74
Appendix v: Mining License	79
Appendix vi: Ultimate Analysis	81
Appendix vii: Major equipment list.....	82
Appendix viii: Commercial CCS facilities and projects worldwide	84

List of Abbreviations and Units

\$	US Dollars
AFR	Air-to-Fuel Ratio
AGR	Acid Gas Removal
ASU	Air Separation Unit
BACT	Best available control technology
bbl	Barrels
BFW	Boiler feed water
Capex	Capital Expenditure
CCS	Carbon dioxide Capture and Storage
CO ₂	Carbon dioxide
COGS	Cost of goods sold
COS	Carbonyl sulfide
CSR	Corporate Social Responsibility
CTL	Coal to Liquids
ECBM	Enhanced coal bed methane
EIA	Environmental Impact Assessment
EWURA	Energy and Water Utilities Regulatory Authority
F-T	Fischer-Tropsch
GCTL	Green coal to liquids
h, hr	Hour
HDPE	High density polyethylene
HHV	Higher Heating Value
HP	High pressure
HRSR	Heat Recovery Steam Generator

GCTL PROJECT Feasibility Report

HSE	Health, Safety and Environment
IGCC	Integrated gasification combined cycle
IP	Intermediate pressure
kg	kilogram
kW	Kilowatt
kWh	Kilowatt-hour
LP	Low pressure
LPG	Liquified Petroleum Gas
m ³	cubic metre
MEML	Maximum Energy and Minerals Limited
MT	Metric tonnes (1 tonne = 1000 kg)
MU	MU Aqua tower
MW _e	Megawatt electricity
MWh	Megawatt-hour
NO _x	Oxides of nitrogen
NPV	Net Present Value
PBPA	Petroleum Bulk Procurement Agency
ppb	Parts per billion
ppm	Parts per million
PSA	Pressure Swing Adsorption
RDI	Research, Development, and Innovation
RF	Recovery Factor
ROI	Return on Investment
scfd	Standard cubic feet per day
SCR	Selective Catalytic Reduction
SO ₂	Sulphur dioxide

GCTL PROJECT Feasibility Report

TPC	Total Plant Cost
tpd	Metric tonnes per day
tph	Metric tons per hour
TZS	Tanzanian shillings
WT	Water treatment
wt%	Weight percent

1. Introduction

Coal-to-liquids (CTL) is a well-known technology that allows the production of liquid fuels from coal. Recent increases in oil prices and security concerns have spurred renewed interest in liquefaction technologies among coal-rich countries.

Main challenges for the CTL technology are:

- High investment costs.
- Uncertainty of long-term oil prices.
- Environmental concerns, particularly CO₂ emissions.

These uncertainties have prompted some governments to give support or plan to provide incentives for the development of a synthetic fuels industry. These may range from loan guarantees via tax credits to import controls and guaranteed production take-off. Commercial coal-to-liquid (CTL) plants are in operation in South Africa, the largest of which produces 160,000 barrels per day (bbl/day) of light olefins and gasoline from coal (Sasol Petroleum International, 2005).

What is Coal-to-Liquids Technology?

The technology of converting coal into liquid fuels goes back into the beginnings of the 20th century, with the Bergius method for direct liquefaction and the Fischer-Tropsch method for indirect liquefaction. Nevertheless, due to high costs and low oil prices, liquefaction found very limited application under stressful circumstances (Germany during WW II, the Republic of South Africa at the time of apartheid). Temporary revival of interest in coal liquefaction came with the 1973 oil crisis, followed by R&D projects developed in Australia, Germany, Japan, the UK, and the USA. However, stabilization of oil prices froze the research, and it took some 30

years and another oil crisis to return to CTL technology as an alternative source of liquid fuels.

Coal is a solid with hydrogen to carbon (H/C) molar ratio of 0.8. This H/C ratio is between 1.3-1.9 for crude oil and around 2 for gasoline and diesel fuel. To convert coal into liquid fuels, it is necessary to introduce the lacking hydrogen into its structure, which can be done either by pyrolysis or – more efficiently – by direct or indirect liquefaction.

There are several different methods of coal liquefaction. The applied technology and the type of coal used have a considerable impact on yield, characteristics, and mixture of products. During the process pollutants of coal such as Sulphur and nitrogen are largely eliminated and produced hydrocarbons are refined in a way like distillation of crude oil. Final products are clean liquid fuels (gasoline, diesel, jet fuel) and other chemical compounds (naphtha, lubricants, Sulphur, ammonia).

Indirect liquefaction is a commercially proven technology, currently used by Sasol (a South African company since early 1980s). During the first stage of processing, coal is gasified with steam to produce syngas (a mixture of hydrogen and carbon monoxide). After removing Sulphur compounds and particles the syngas is reacted over a catalyst at a relatively low pressure and temperature. Final products depend on the type of reaction and on the catalyst. Indirect liquefaction is characterized by ultra clean fuels and is well suited for Carbon dioxide Capture and Storage (CCS).

Direct liquefaction is a potentially more effective way (overall energy efficiency is in the range of 60-70%), and it has been chosen for the Chinese Shenhua project. There are a couple of different variations of technologies, yet the main features of the process are the dissolution of coal in a hydrogen-rich solvent at high temperature and pressure and further hydrocracking with a catalyst. Apart from

higher efficiency, this method allows adjusting for the type of product necessary and produces fuels of high energy density. Obtained oil products require refining before going to the market. Drawbacks of this method are higher operating costs and higher CO₂ emissions.

Can Tanzania Benefit from Its Coal?

Tanzania is believed to have the largest coal reserves in East Africa (over 5 billion tons - Explored 1.9 billion tonnes) and a very small percentage of its coal is utilized, mainly domestic. Tanzania is heavily dependent on foreign importation of liquid fuels. Rising world fuel prices is a major concern to the Republic of Tanzania's energy security. CTL provides a window to utilize and benefit from domestic production of liquid fuels.

Maximum Energy and Minerals Limited Company is planning to build a 20,000 barrels per day green coal to liquids (GCTL) plant in Ludewa district Njombe region in Tanzania. Maximum Energy and Mineral Limited Company owns a reserve base of 323.18 million tonnes of bituminous coal, and therefore committed to bring this project to life. The planned plant is expected to reduce Tanzania's dependency on imported oil by approximately 34%. Using advanced technology maximum energy is planning a net zero CO₂ emission plant by 2030. To achieve this, Maximum Energy will introduce a technology for Carbon dioxide Capture and Storage for Enhanced production of Coal bed methane (CCS-ECB).

The plant design includes gasification technology and an F-T reactor system using an iron-based catalyst. The design includes a cluster of two gasification plants, each containing two gasifier trains for a total of four gasifiers. The F-T plant contains reactors, hydrotreating units and hydrocracking units capable of producing 12,000 bbl/day of commercial-grade diesel liquid and 8,000 bbl/day of

gasoline liquids. The CTL plant also generates electric power, mostly for internal use with excess (About 50 MW_e net) to be exported to the grid or sold to a neighboring country. The plant design includes provision for future installation of equipment to capture and compress carbon dioxide to 150 barg for injection into deep coal seams layers.

This report details the technical and economic assessment of the CTL plant, and includes conceptual design assumptions, equipment descriptions and lists, process flow diagrams, heat and material balances, and energy and performance summaries. Also included are estimates of capital, operating and maintenance costs, and a financial analysis of the commercial viability of the concepts under various sets of economic assumptions.

2. Technology Consideration

2.1 Reserve Estimate

The basis for reserves estimation began with a detailed geological mapping of the observed outcrops, then core diamond drilling, lateral and vertical testing followed by conceptual geological modelling of the formations. A total of 12 wells have been drilled and 9 of them returned with a significant economic coal seam. According to geological technical report, the coal seams consist of moderate grade rank coal. The weighted average of the coal seam within the resource area is 1.13% moisture, 22.3% ash, 6.452 kcal/kg heating value and 1.15% Sulphur. The total measured and indicated coal resource is 323.18 million tonnes, of which 112.45 million tonnes are in the measured and 210.73 million tonnes are in the indicated categories. In addition, there is 189.87 million tonnes in the inferred category (Buluma & Ndonde, 2021). This is summarized on Table 2 below:

Table 2: Ludewa Coal Seam Resources

COAL SEAM RESOURCES (in tonnes)				
Coal Seam	Assurance of Existence Category			Total Measured and Indicated
	Measured	Indicated	Inferred	
Upper Coal Seams	101,082,400	166,631,100	157,832,500	267,713,500
Lower Coal Seam	11,368,145	44,097,255	32,039,200	55,465,400
Total	112,450,545	210,728,355	189,871,700	
Total Measured and Indicated	323,178,900			

In this case,

Recovery Factor (R.F) based on the technical report

$R.F = [\text{Reserve Base} - (\text{Mining Loses} + \text{Cleaning Loses})] / \text{Reserve Base}$

GCTL PROJECT Feasibility Report

Reserve Base = Measured + Indicated Resources = 323.18 million tonnes

Estimates due to drilled well data:

Mining Losses = 9%

Cleaning Losses = 22%

R.F = 69%

Recoverable Reserves = **223 million tonnes**

There is even a larger area that need to be mapped and explored, the reserves may be more that what is seen now.

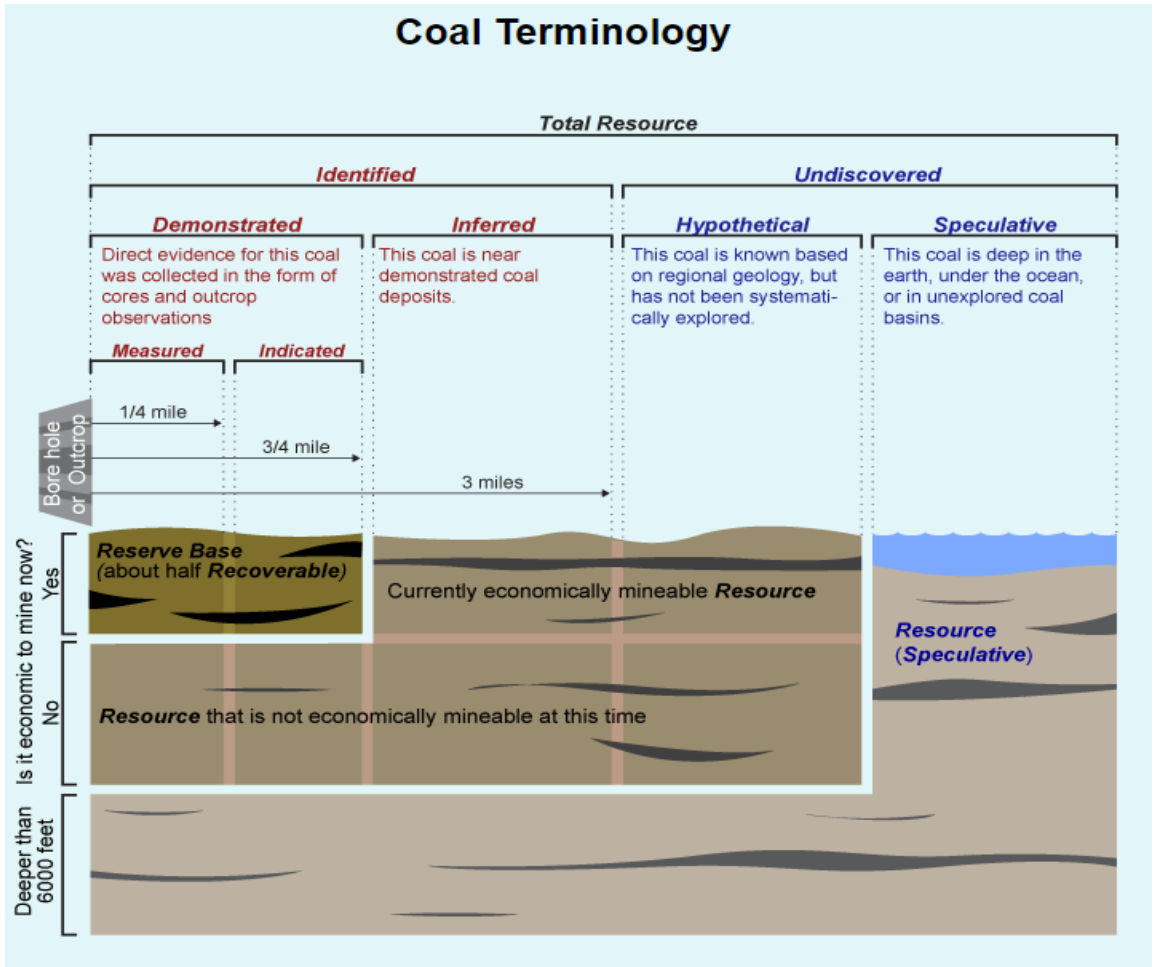

Figure 1: Recoverable Reserves Estimation (David Coil; Erin McKittrick; Bretwood Higman, 2012)

2.2 Clean Coal Technologies and Environment

This project will promote the use of Clean Coal Technologies (CCT) such as high efficiency of coal gasification and zero-emission technology to reduce the greenhouse gas emitted from the plant. CCTs are a range of technological options

which improve the environmental performance of coal. Different technologies have been developed to tackle different environmental impacts – from tackling air pollution, to cutting CO₂ emissions and reducing water usage. These technologies mitigate the environmental impact of coal from mining through to end use.

The wider use of technologies to improve the environmental performance of coal is essential and will be utilized in this plant. Tanzania is one of the developing countries where coal use is set to increase. This is particularly the case for technologies that cut CO₂ emissions, such as carbon capture, utilization, and storage (CCUS), which are critical to meeting our climate objectives. Figure 2 below shows clean coal technologies.

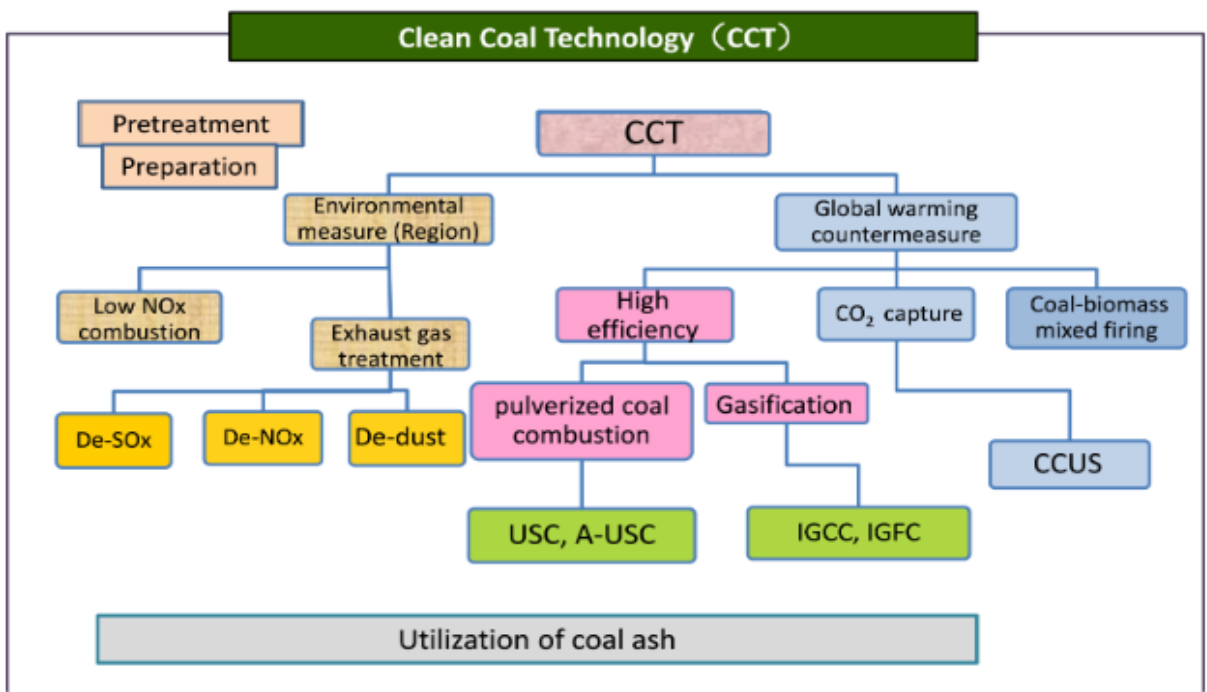

Figure 2: Clean Coal Technologies

2.2.1 Plant Inputs

The planned green coal to liquids (GCTL) plant inputs are 11,000 tonnes per day of coal and water 5,500 tonnes/day, the coal will be mined using modern and environmentally friendly mining technology followed by rehabilitation of the mined areas, the project will plant vegetations, gardens, playgrounds, and recreation areas. The plant is close to two rivers Ruhuhu and Katewaka rivers, initially the plant will utilize the water from the rivers but in 5 years' time the plant will use underground water following a closed cycle plant following its energy transition plans.

2.2.2 Plant Outputs

Gasoline and diesel are the main commercial products amounting to 20,000 barrels per day. There will be core generated electricity from steam turbines and tail gas. The electricity will be enough to run the plant with a net excess for sale of 50 MW_e. Another important product is Sulphur amounting to 87 tonnes/day. This will carefully be separated and processed for further use. Produced Sulphur will be sold to Agrochemical and fertilizer industry both domestically and internationally. Tar/slag will be incombustible and will be utilized in construction industry to make bricks, roads, pavement blocks etc.

2.2.3 CO₂ and CCS

Carbon dioxide is a major concern to the environment, but our energy transition plan, mitigates the impact. The CTL plant is planning a CO₂ net zero plant withing 5 years of operation. This can be achieved by carbon dioxide capture and storage (CCS). There is a big potential for CCS in Tanzania and the project will set aside enough budget for further research and studies on this. CCS technology is currently picking up especially in developed countries. There are several ways CCS has been conducted. For instance, CO₂ can be injected and stored in depleted oil and gas

reservoir, can be used to enhance oil recovery, can be captured, compressed, and injected (stored) in deep unused saline water-saturated reservoir rocks (aquifers), can be stored in deep unmineable coal seams, can be used in enhanced coal bed methane recovery and other options like basalts, oil shales & cavities. Figure 3 shows geological CO₂ storage methods.

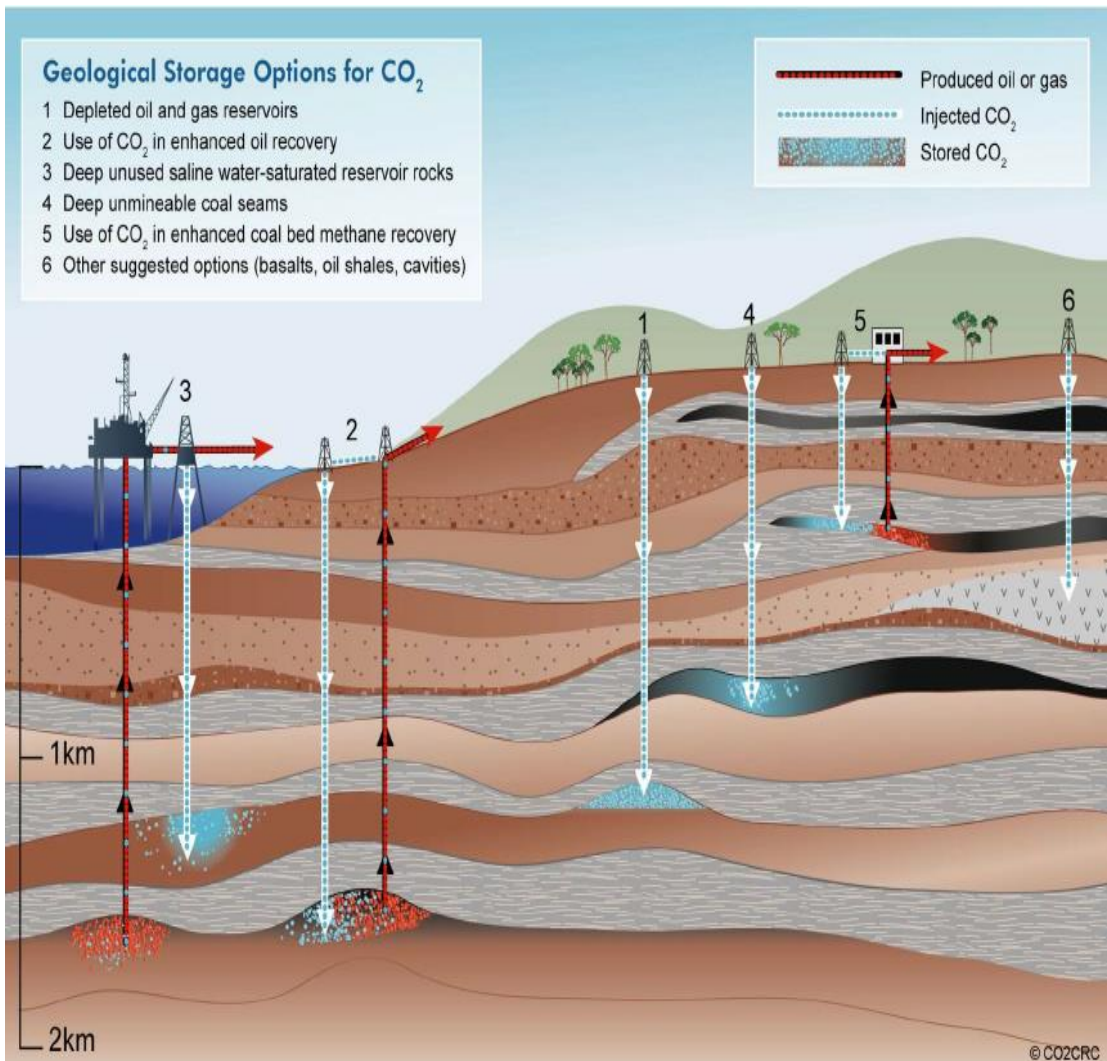

Figure 3: Geological CO₂ storage methods (IPCC, 2005)

The deeper the storage site the better the CO₂ chemical behavior due to increasing pressure with depth. At supercritical point, approximately 1 km of depth, the volume is reduced from 100 volumes to 0.28 volumes. See Figure 4 below.

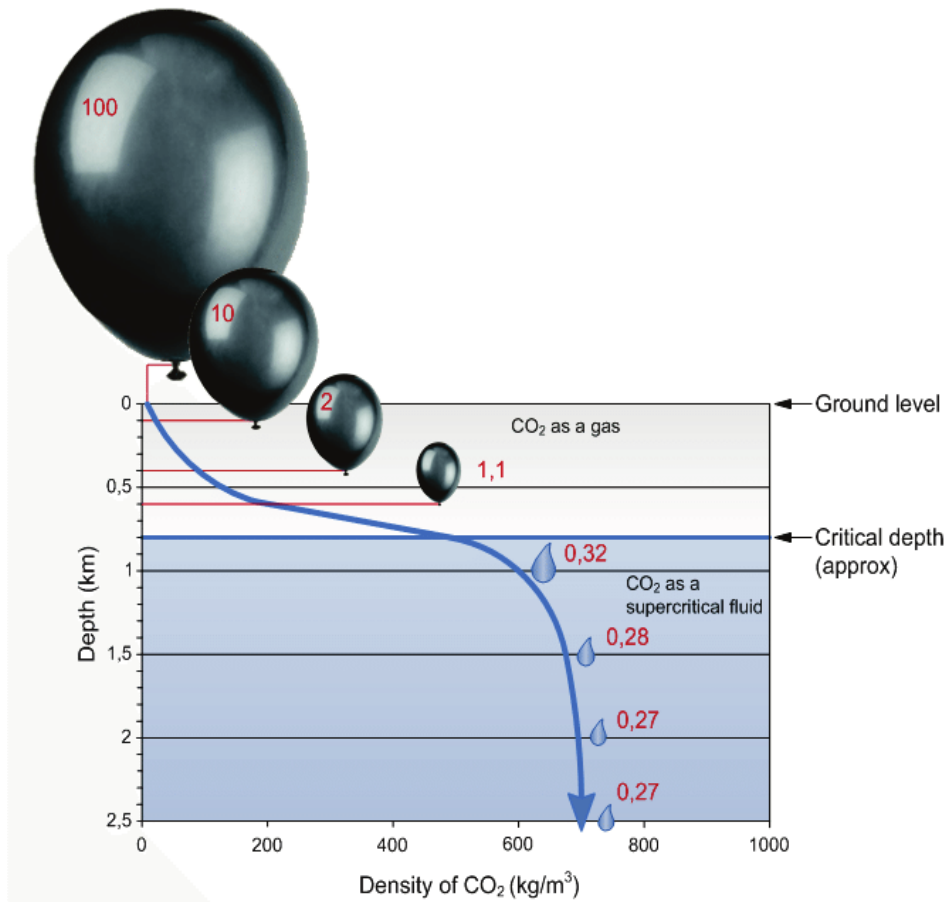

Figure 4: CO₂ volume change with depth

2.2.4 Global CCS Overview

Carbon capture and storage (CCS) continues to make significant progress around the world against a backdrop of greater climate action from countries and private

companies. The Global Status of CCS 2021 demonstrates the critical role of CCS as nations and industry accelerate to net-zero. There are now 135 commercial CCS facilities in the project pipeline (27 are fully operational) from a diverse range of sectors including cement, steel, hydrogen, power generation and direct air capture (Global CCS Institute, 2021). Appendix viii shows an overview of planned and operational CCS projects worldwide.

2.2.5 CTL Energy Transition Plan

The company will set aside a budget of more than \$15 million per year. The budget will be used to first explore the deeper layers of coal for a possible CO₂ injection with enhanced coal bed methane production. 2D/3D Seismic acquisition, processing and interpretation followed by drilling exploration wells. The plan is to inject CO₂ in a separated area inside our Ludewa mine. This process will also produce water, that can be cleaned and utilized with the CTL plant. The green coal to liquids plant will be a closed system, producing its own electricity and water, while handling CO₂. An epitome of green life, zero CO₂ emission with a possible methane production. Figure 5 depicts the CO₂ enhanced coal bed methane production concept.

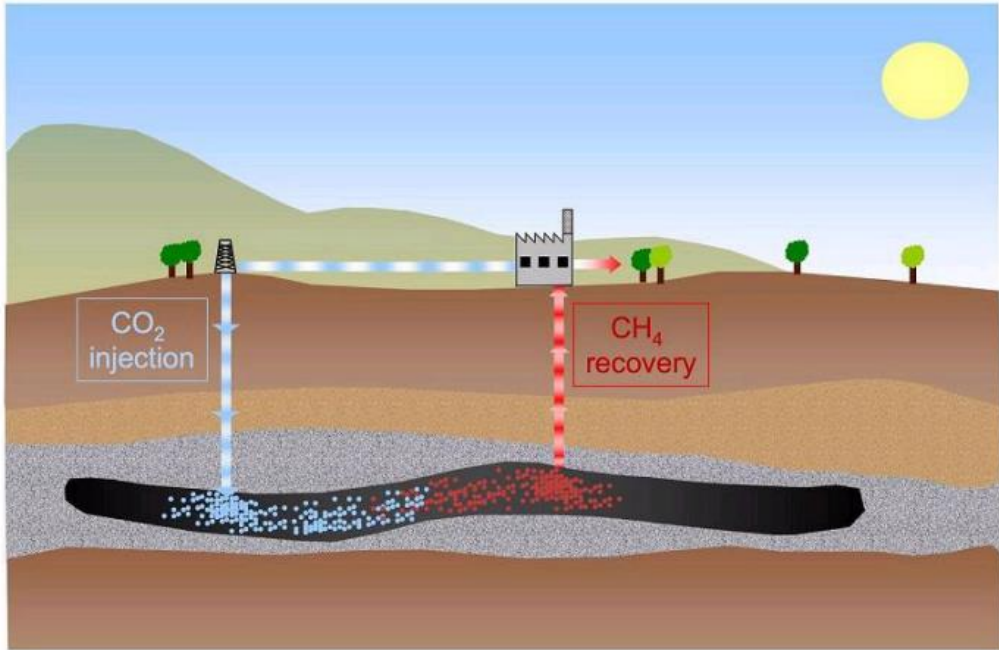

Figure 5: CO₂ – Enhanced Coal Bed Methane Production concept

2.3 Environmental Impacts and Mitigation

Most of the expected environmental impacts will be mitigated through sensible and advanced technology method. The plant will utilize water from Katewaka river for the first 5 years then underground water will be utilized while injecting CO₂ and producing coal bed methane. The mining area will be reclaimed by bringing new soil and planting vegetation, recreation areas and playgrounds will be constructed. The mine and the CTL plant are carefully designed to bring beauty to the environment, the first of its kind in Tanzania, green in nature, will also bring tourism as one of its products. Table 3 below summarizes the impacts:

Table 3: Summary Environmental Impacts and Suggested Mitigation Measures

No:	Environmental Impact	Mitigation
1	Coal Dust and Particles (while grinding)	Water will be used to make slurry; no dust will be formed.
2	Water	<ul style="list-style-type: none"> - Wastewater treatment before releasing or recycling. - The Katewaka river water will be utilized in the first five years, then underground water will be utilized, accompanying ECBM.
3	Carbon dioxide (CO ₂)	<ul style="list-style-type: none"> - Efficient F-T and gasification recycle streams with better conversion of coal and less CO₂. The process produces less CO₂ compared to traditional coal combustion methods. - However, carbon dioxide produced will be captured and stored underground (CCS) in the deeper coal seams layers with enhanced coal bed methane (ECBM) production. This process is planned to take 5 years before implementation.
4	Sulphur	The produced Sulphur will be Separated and processed for sale. The potential customers are agrochemical industry, fertilizer factories, rubber vulcanization for tire factories etc.
5	Tar/Ash	This is non-combustible and can be used in Construction materials, bricks, roads, pavement blocks, playgrounds, etc. There is an extended value chain to utilization coal tar/ash.
6	Nitrogen Oxides (NO _x)	This plant will use Oxygen from air, we will introduce Air Separation Units (ASU) to separate Oxygen from air and thus avoid Nitrogen in the system.

2.4 Plant Design Basis

2.4.1 Site Description

The characteristics of the site for plant establishment are presented in Table 4 and Table 5.

Table 4: Generic site ambient conditions

Parameter (unit)	Value
Elevation (m) /Altitude ASL	618
Barometric pressure (atm)	0.926
Design ambient temperature (°C)	20
Design ambient relative humidity (%)	60

Table 5: Generic site characteristics

Location	Ludewa coal mine
Topography	Level
Size (acres)	100
Transportation	Mainly road, and railway
Ash/Slag disposal	Off site, used for construction materials
Water	River nearby
CO ₂ storage	Future sequestration

The remaining design parameters are not quantified in the studies because they may be unique to the site. However, cost estimates of plant construction are included in our financial analysis and assume normal conditions.

2.4.2 Design Fuel Characteristics

The design coal for this plant analysis is Ludewa coal. Table 6 presents the coal characteristics.

Table 6: Ludewa design coal

Rank	High Volatile Bituminous	
Source	Maxcoal Ludewa coal mines	
Proximate Analysis (wt%)		
	As Received basis	Dry basis
Moisture	3.90	0.00
Ash	15.39	15.99
Volatile Matter	31.13	32.34
Fixed Carbon	49.58	51.67
HHV (kcal/kg)	6039	6542
Ultimate analysis (wt%)		
	As Received basis	Dry basis
Ash	15.39	15.99
Carbon	73.91	76.79
Hydrogen	4.56	4.74
Moisture	3.9	0.00
Sulphur	1.50	1.56
Oxygen	0.74	0.92
Total	100.00	100.00

2.4.3 Environmental Requirements

The conceptual design considers technology that conforms to BACT guidelines. Following the nature of the design coal we expect carbon dioxide and Sulphur as the prominent pollutant in the plant effluent.

The plant consists of a carbon dioxide capture in the acid gas absorption section. Carbon dioxide is captured by amine solvents and stripped off the raw syngas. The carbon dioxide produced can be used and sequestered. Our plant design does not include CO₂ transport and sequestration systems.

The control technology to ensure nonhazardous Sulphur emissions in our design concept is solvent adsorption using Selexol and followed by elemental Sulphur recovery plant using the Claus process. The limit is not less than 99% of Sulphur recovery.

Raw water usage is another environmental concern. The plant will have an evaporative cooling tower, where all process blowdown water streams are treated and recycle to these cooling towers. The raw water from a local river is meant to supply makeup water to this process water cycle.

2.5 Plant Analysis

2.5.1 Assumptions for Plant Analysis

The plant design concept is based on a generic location in Tanzania, where xxx is used as the design coal.

The design of the gasification system is based on a combination of custom Aspen Plus models and referencing previous similar operation and design open-source information. The gasification system consists of a multi-train slurry feed entrained gasifier configuration. The configuration consists of 2 gasifiers per train. An acid gas removal system in place uses Selexol solvent absorption done in 2 stages to remove Sulphur gas components and carbon dioxide. Further, Sulphur recovery is done by a Claus Sulphur recovery system. The syngas is converted to hydrocarbons in a Fischer-Tropsch (F-T) reactor system consisting of a slurry-bed, iron-based catalyst. The F-T reactor system analysis was also performed by a combination of

simple custom developed model in simulation software Aspen Plus and referencing from public information. This analysis considers only carbon dioxide capture but not sequestration.

2.5.2 Analysis of Plant Concept

The plant concept is a coal to liquids (CTL) facility that receives syngas originating from two dual train gasification systems to achieve maximum load operation.

The following assumptions and base parameters were drawn for this study:

- i. The plant will satisfy its own electric power requirements and is expected to produce excess electric power that is to be exported to the grid.
- ii. The F-T system uses a combination of recycle streams and other unit operations that aim to maximize liquid fuels production.
- iii. The F-T system includes upgrading operations that are fully capable of producing commercial grade diesel and gasoline. The diesel and gasoline can be stored and transported to a distributor or treated with additives and sold to the end-user.
- iv. The nominal plant capacity is a production rate of 20,000 bbl/day of F-T liquids.
- v. The plant will be located at Masimabarafu village in Ludewa district, Njombe region.
- vi. The design analysis does not include the estimates of equipment costs required of exporting electric power to the grid.
- vii. The plant will consist of a hydrocracking unit necessary to convert wax F-T product into a liquid product that can be sold to refineries.
- viii. The gasifiers employed have appropriate environmental and safety control systems that conform to air quality regulations and standards.

- ix. Electric production is optimized to generate as much net power as possible while maintaining the plant power self-sufficiency.
- x. The F-T reactor will assume the latest available technology for slurry-based reactor systems using high alpha iron (Fe) based catalyst.
- xi. The plant employs carbon capture technology aimed at future carbon sequestration to achieve sustainable production.

2.5.3 Process Description

The aim of the process is to achieve maximum liquids production from the F-T reactor. The design includes a recycle stream of unconverted syngas after CO₂ removal. Figure 6 is the detailed process flow diagram describing the entire plant process.

From Coal to Syngas

At the beginning the process converts coal into syngas. The conversion is done by a gasifier that uses Ludewa coal as fuel. Before entering the gasifier, the coal is pulverized in a fine mill to a particle size distribution of mean 0.5 mm and less than 1.5 mm. The pulverized coal is mixed with treated water in a mixing tank to form a coal slurry and stored temporarily for gasifier feed. The gasifier is a two-stage oxygen-blown, entrained flow, refractory-line gasifier which has continuous slag removal. The coal slurry is fed into the gasifier and reacts with oxygen at about 1600°C. A 95% purity oxygen stream supplied to the gasifier is obtained from an air separation unit (ASU). After partial combustion of coal at an air-to-fuel ratio (AFR) of about 0.4, syngas is produced and is cooled after leaving the gasifier (Hillestad et al., 2018). The syngas cooling heat exchanger produces high-pressure steam. The raw syngas is quenched and further cooled in a water scrubber to remove particulates and trace components.

We expect trace amounts of nitrogen in our syngas due to the absence of nitrogen in the ultimate coal analysis report. However, due to the sensitivity of catalysts, adsorbents, and solvents in the downstream process to sulphur and cyanide compounds, a control system is installed in the plant. The raw syngas stream is slightly re-heated and passed through a COS hydrolysis reactor to remove COS and HCN by hydrolyzing it to H₂S. Then an additional cooling is done to remove produced water and ammonia (NH₃). The syngas is passed through a heavy metal removal system which consists of a sulphur-impregnated activated carbon adsorption bed. Metals such as mercury and arsenic are removed. The type of coal used in this analysis does not constitute these elements, but they are considered since they may appear in traces and in varying amounts in the feed. It is important to remove these heavy metal elements to avoid catalyst deactivation.

The syngas is “sweetened” by removing the acid gases H₂S and CO₂. This happens in two stages. The first stage involves removal of H₂S by a Selexol process from the cool, particulate-free gas stream. This leaves a product stream rich in CO₂. The absorbed H₂S is stripped and transported to a Claus plant for elemental sulphur production. At the second stage of the Selexol process, CO₂ is removed from the syngas and the stripped gas is dehydrated for compression and storage. The exit syngas from the Selexol process contains at most 1 ppm total sulphur. To further reduce the sulphur concentration in syngas to below 1 ppb, it is passed through a zinc oxide polishing bed. Then sweet syngas is obtained that is the feed for the F-T process.

From Syngas to F-T Liquids

Clean syngas from the gasifier is fed into the F-T slurry reactors to produce the hydrocarbons. The F-T reactors cannot achieve a conversion of greater than 70% per pass and therefore, the design includes recycle streams of the unconverted

syngas exiting the reactors. The reactor is water cooled and hence generating steam for more power generation. The effluent stream has two phases, the liquid phase stream is cooled and flashed. Then it is sent to the distillation column.

The vapor phase streams from the F-T reactors are cooled. It generates a condensate with aqueous and hydrocarbon liquid phases that are separated. The liquid hydrocarbon phase is further cooled and sent to the hydrocarbon recovery section. Since CO₂ is also a byproduct of the F-T reaction, it is separated from the vapor phase stream by the CO₂ removal unit. The CO₂ rich vapor is passed through an amine to generate a CO₂ lean vapor which is then sent to the hydrocarbon recovery plant. The hydrogen recovery plant produces high-purity hydrogen that is used in the product upgrading processes. Hydrogen is recovered by pressure swing adsorption. The vapor stream then enters an autothermal reformer that combines the remaining light components with steam and oxygen to form syngas and minimize accumulation of the light ends in the recycle loop.

Product Upgrading and Refining

The distillation column separates the F-T liquid products into light components, naphtha, distillate, and wax fractions meant for further processing. All light end products that are C4 or lighter are used as fuel for a combustion turbine. The naphtha fraction is catalytically hydrotreated to form a stable naphtha which is then upgraded to gasoline. The distillate fraction is also catalytically hydrotreated to produce diesel. The bottoms which is the wax fraction is catalytically hydrocracked to produce diesel and gasoline cuts.

The F-T process converts coal gasified syngas to produce 20,000 barrels per day of liquids in total, 8,000 barrels per day of gasoline and 12,000 barrels per day of distillate. The distillate is combined with additives to generate a blend of market

grade diesel fuel. The liquids are stored in the storage farm in the facility and another fraction is transported by truck fleet to a storage facility with access to rail and regional trunk roads.

The off-gas from F-T process is compressed and used as fuel for a gas turbine that will produce a total of 113 MW_e auxiliary power. The hot flue gas exiting the gas turbine is passed through a HRSG where superheated high-pressure steam is generated and combined with that generated from cooling of the syngas stream from gasification process and that generated by recovered heat from F-T reactor cooling which in total produces 221 MW_e when expanded in a multi-stage steam turbine. The nominal net plant power that can be exported after deducting all auxiliary power loads is 50 MW_e.

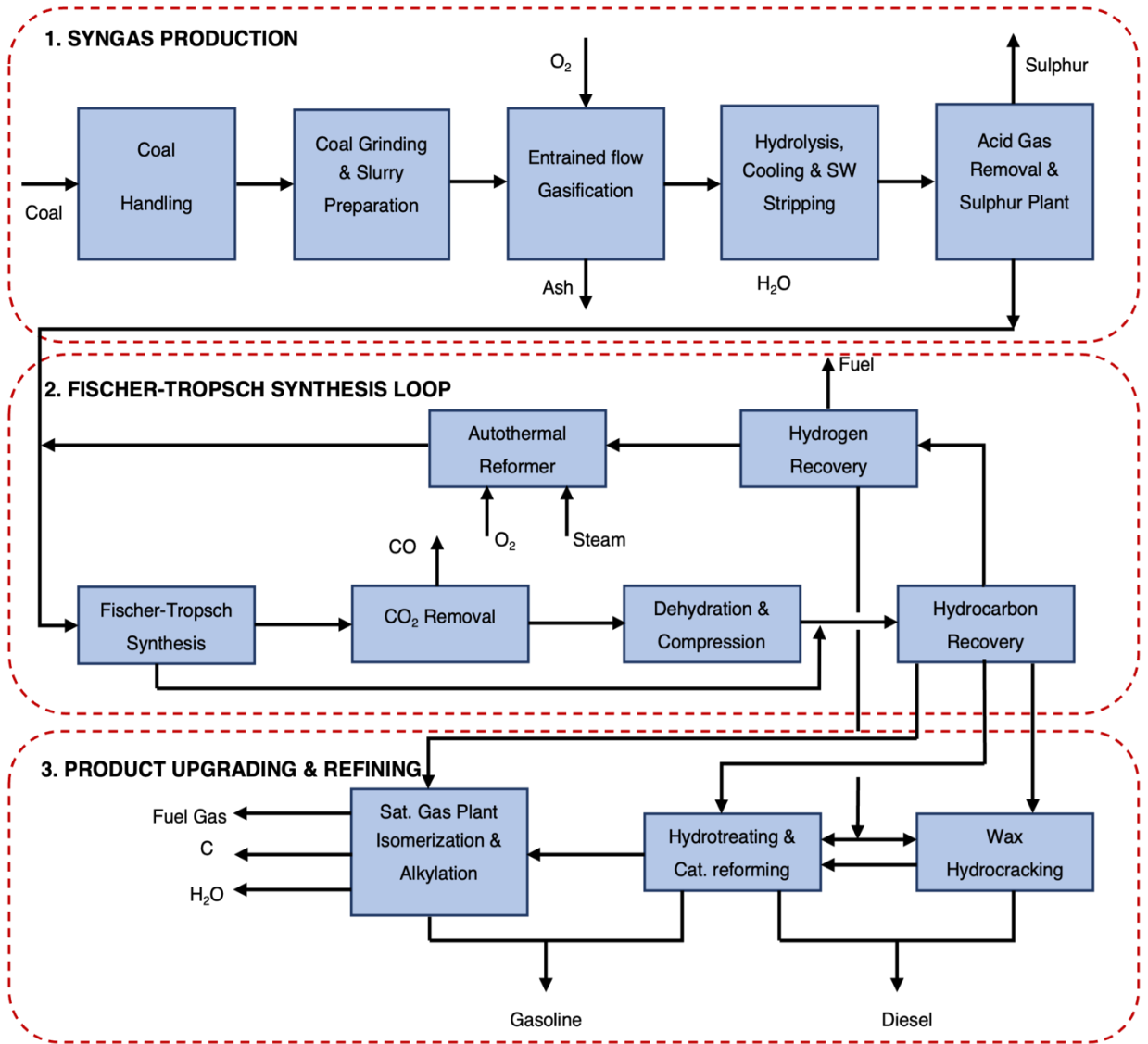

Figure 6: Overall process configuration

2.6 Plant Design

2.6.1 Description

The Green coal-to-liquids (CTL) plant is designed to produce about 20,000 barrels per day of Fischer-Tropsch (F-T) liquids using about 11,000 tonnes per day of near-

site Ludewa coal. To handle such throughput and coal feed, we design a plant concept that has a cluster of two gasification plants, and each gasification plant containing two gasifier trains. The clean syngas from the two units is joined by a central manifold to be distributed to the F-T plant. Therefore, we suggest that each gasification plant is located on either side of the plant site and the F-T plant should be placed centrally. The plant concept of the clusters of gasification plants is shown in Figure 7.

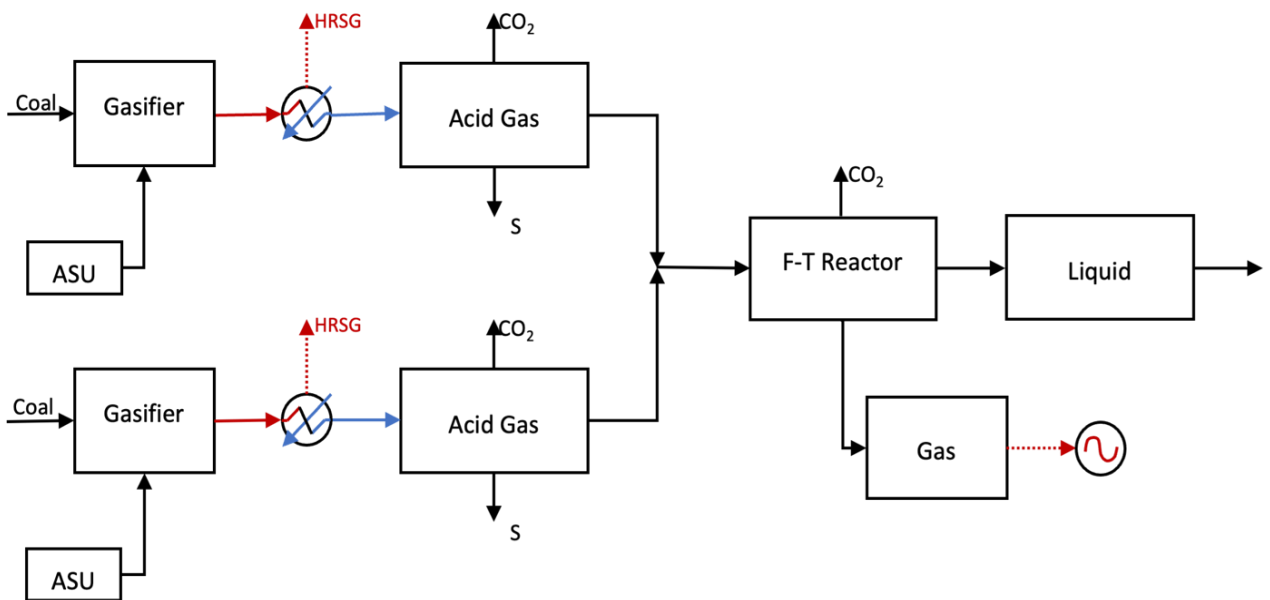

Figure 7: Plant design concept with two gasification clusters

In each gasification train are two oxygen-blown entrained flow two-stage gasifiers that produce the syngas. The oxygen feed to the gasifiers is separated from air by two air separation units (ASUs), one for each cluster. Gas exiting the gasifiers are combined and cooled by fire-tube heat exchanger producing high pressure steam.

Then the cooled gas is cleaned of particles by a cyclone collector and a ceramic candle filter. To further reduce particulates and trace components, the raw syngas is passed through a spray scrubber. The scrubber may capture slag that is recovered in a slag recovery unit.

The gas is further cooled and cleaned by several processes. These include COS hydrolysis reactor, an activated carbon bed for mercury and heavy metals removal, and a two-stage Selexol Acid Gas Removal (AGR) system. H₂S is removed from the cool and clean gas by the Selexol process leaving a rich CO₂ process stream. The stripped H₂S is converted to elemental Sulphur by a Claus plant. Then the rich CO₂ syngas stream is stripped in the second stage of the Selexol absorber, dehydrated and may be compressed for possible storage.

The clean syngas is further reduced of Sulphur concentration from <1ppm to <1ppb by a zinc oxide Sulphur polishing bed. This syngas reacts in the F-T reactors to produce hydrocarbons, and the conversion is enhanced by recycling the reactor off gas stream. CO₂ is removed from the F-T gas product stream and combined with the one above. The F-T process produce 20,000 barrels per day of hydrocarbon liquids that consists of gasoline and diesel components. Wax is hydrocracked catalytically to generate the desired F-T liquids and the lighter ends are used to generate power by gas turbines. However, C₃ and C₄ components can be separated to form LPG that has a strong commercial value. Additives are blended with the diesel fraction to match the commercial-grade properties of saleable diesel. These additives control the products pour point, viscosity, stability, and corrosion effect.

The remaining light ends (<C₄ if LPG is not sold, or just <C₂) form the fuel gas that is collected form the F-T reactors, compressed, and sent to the gas turbine to

generate auxiliary power. The hot flue gases generate high pressure steam that drive the heat recovery steam generators (HRSGs), where the steam is expanded in a multi-stage turbine and generate additional electric power.

2.6.2 General Description of the Process Systems

Here is a more detailed description of the process and their process specifications and requirements.

Coal Grinding and Slurry Preparation

Coal feed from vibratory feeders enter a conveyor that is below each coal storage silo. The coal is delivered to a rod mill hopper via an inclined conveyor. The feed hopper provides a nominal buffer capacity of approximately 2 hours. Each feed hopper has 2 outlets that supply the weigh feeder, which then feeds a rod mill. One rod mill has a process capacity corresponding to 66% of the coal feed required by the gasifier. The specification of the crushed coal is a particle size distribution of mean 1 mm and a maximum size of 1.5 mm. The rod mill crushes and wets the coal with treated slurry water. The slurry water originates from a slurry water tank and is transported to the mill by slurry water pumps. A coal slurry mixture is discharged into a rod mill product tank. The slurry is then pumped from the rod mill product tank to a slurry storage and slurry blending tanks.

The coal grinding units are installed with dust suppression systems that spray water. Moreover, all the storage tanks are equipped with agitators to maintain the slurry solids in suspension.

The selection of fabrication materials used in the systems in this plant section must consider the abrasive conditions present. The storage tanks and agitators must be rubber lined. Slurry and slurry water pumps can be rubber lined and/or

constructed by hardened metal for erosion reduction. Fluid piping for slurry and slurry water transport is made of high-density polyethylene (HDPE).

Entrained Flow Gasification

A two-stage oxygen-blown entrained flow gasifier with refractory material lining is selected. The gasifier also has a continuous slag removal system in place. The gasifier is fed with a 66 wt% dry coal/water slurry at an 80%/20% split to the first and second gasification stages, respectively. The slurry reacts with 95% purity oxygen at 1600°C and 40 barg in the first stage. The coal is partially combusted, producing heat that speed up the gasification reactions, and melt the ash to flow. The 95% purity oxygen is obtained from an air separation unit.

The primary gasification zone – corresponds to the first stage – has operating temperatures of between 1200°C – 1600°C which exceeds the melting point of ash. This ensures that ash can be removed as molten slag. The temperature in the gasifier is regulated by the oxygen feed flowrate and flowrate of recycled stream containing tail gas from downstream processes.

The molten ash exits through the bottom of the gasifier into a water quench where it forms an inert glass-like slag. The gaseous products from the first gasification stage flow up into the secondary zone, which occurs in a vertical refractory lined vessel.

22% of the slurry is preheated and atomized by spraying into the gaseous product stream to obtain a full slurry quench. Since the gasification and heating of atomized slurry is endothermic, the temperature of the gaseous mixture in this zone is lowered to about 1000°C – 1200°C, and that is the exit temperature after the second stage.

The second stage produced char that is entrained in the exit fuel gas stream. A combination of cyclones and candle filter particulate control units are used to separate the char from the fuel gas. This char is recycled back to the first gasifier stage.

Raw Gas Cooling

High temperature raw gas exits the gasifier from the secondary gasification zone at a pressure of 40 barg and about 1200°C. The hot gas stream is cooled further down to 350°C in a fire-tube boiler. This can also be termed the waste-heat boiler that traps the “waste heat” in form of high-pressure steam while cooling the raw gas. The steam was originally boiler feedwater that becomes saturated and then forms part of a heat recovery system – a Rankine cycle – to provide steam to the steam turbine.

Particulate Removal

After the gasifier, a cyclone and a ceramic candle filter are placed in series to control the particulate concentration in the exit raw gas stream. The particles are basically char and fly ash, that once separated are recycled back to the gasifier. The filter is composed of ceramic candle elements confined in a pressure vessel. The filter is cleaned periodically by back pulsing it with fuel gas to remove the fines material. Raw gas exits the candle filter at 350°C and between 30 – 35 barg. Alkali and volatile metals are also left in this filter since most of them start to condense on the particles at temperatures below 550°C.

Gas Scrubbing

The gas exiting the particulate filter unit mainly contains CO₂, CO, H₂, water vapor, N₂, and relatively smaller amounts of CH₄, COS, H₂S and NH₃. Due to the acidic gas impurities, this particle clean gas is termed “sour” gas.

After gas cooling at 350°C, it passes through a scrubber to further remove particulates. The syngas is washed by two counter-current flow packed bed quench scrubbers. This exit gas stream is required to have less than 1 mg/m³ of residual soot. The scrubber removes the traces of entrained particles from the gasifier which may include slag, metals, and unconverted carbon. It also scrubs out soluble trace compounds such as NH₃, HCN and halides. The solid bottoms from the scrubber are transported to the slag removal and handling system for processing. The liquid exit stream is sour water which is first stripped of sour gas and then pumped to the wastewater treatment plant before being recycled.

Sour Water Stripper

This equipment is necessary to remove NH₃, SO₂ and other impurities from the sour water waste stream of the scrubber. The system consists of a sour water accumulator drum that collects and temporarily stores sour water before sending it to a packed column sour stripper, equipped with a steam-heated reboiler. The sour gas stripped from the scrubber wastewater is sent to the sulphur recovery unit and the remaining water is sent to wastewater treatment.

Mercury Removal

This unit may be installed or not depending on whether the coal produces significant amounts of heavy metals commonly mercury (Hg), or arsenic (As). If the heavy metal amounts produced are below the allowed threshold according to standards, then this unit might be unimportant. When the amount is significant, the metals are removed by sulfur-impregnated carbon packed beds. A 95% mercury reduction can be achieved by a dual packed bed with about 20-second superficial gas residence time.

Acid Gas Removal

This plant consists of a Selexol unit where CO₂ and H₂S are simultaneously recovered from the gas stream. The separation technique is to first remove H₂S preferentially as a product followed by CO₂ and the remaining H₂S as a fraction of it. Since there are two stages involved, this is a two-stage Selexol unit.

The dry and particulate-free syngas at 35°C and 25 barg enters the first absorber for H₂S removal. The lean Selexol solvent preferentially absorbs H₂S because it is already loaded with CO₂. The rich solution at the bottom is regenerated in a stripper by a low-pressure steam-driven reboiler.

The sweet flue gas is cooled and pumped to the second absorber where it is contacted with an unloaded lean Selexol solvent. The solvent absorbs CO₂ at more than 95% efficiency together with most of the remaining H₂S. The stripped solution is then regenerated to produce sulphur-rich gas that is fed to the Claus plant. Sweet gas from stage two absorption is polished in a zinc oxide (ZnO) packed bed to further reduce the sulphur content for the Fischer-Tropsch reactor feed to not more than than 1 ppb.

CO₂ compression

This unit aims at compressing the recovered CO₂ in the absorbers for transport, storage and/or sequestration. The rich solution from the Selexol unit is flashed in three stages at different pressures of 20 barg, followed by 10 barg, and then 2 barg. Approximately 20%, then 25% and finally 55% of the CO₂ is flashed from each stage, respectively. The low-pressure CO₂ stream is compressed to 11 barg and then merged with the 10 barg CO₂ stream. The higher-pressure CO₂ is sent to the compressor at an appropriate compression stage when the combined flow is compressed in a multi-stage compressor unit to 150 barg. The multi-stage

compression is intercooled to supercritical conditions. While compressing the CO₂ is dehydrated to -40°C using triethylene glycol. The moisture-free supercritical CO₂ is then ready for pipeline transport.

Claus Plant

The Claus plant receives all the acid gas collected from each of the Selexol unit strippers. The Claus process involves partial oxidation of H₂S fraction of the acid gas to elemental sulphur. At a recovery efficiency of 99.5%, the plant recovers about 87 tonnes of elemental sulphur per day.

When the acid gas enters the Claus unit, it is first preheated to 230°C. Then a portion of the acid gas and the oxidant are all fed to the Claus furnace. The furnace catalytically oxidizes H₂S to SO₂ with the 95% pure oxygen from the ASU. The furnace temperature must be maintained at 1300°C. At this temperature, NH₃ will be decomposed from the sour gas stream and steam at 43 barg will be generated from the heat recovery. The generated steam is capable of satisfying preheating and reheating requirements within the Claus plant. The plant requires three preheaters and three sulphur converters to obtain a per-pass H₂S conversion of 98%.

Air Separation Unit (ASU)

Each ASU produces a rated output of 5000 tonnes of 95 mol% of O₂ per day to be used in the gasifiers and Claus plant. The ASU also recovers about 10000 tonnes of N₂ per day that is compressed and sent to the gas turbines as a diluent for mitigating NO_x formation.

The air feed to the ASU is provided by a stand-alone air compressor. The air is filtered then compressed in a multi-stage intercooled centrifugal compressor. The

air stream is cooled and then fed to an adsorber pre-purifier for further purification.

The air exiting the pre-purifier is split into three streams. First, about 70% is fed directly to the cold box. Then 25% of the air is compressed in an air booster compressor. The boosted air is cooled against cooling water in an aftercooler before it is fed to the cold box. Finally, the remaining 5% of air is fed to a turbine-drive single stage centrifugal booster compressor. Then this stream is cooled in a shell and tube heat exchanger by cooling water before it is fed to the cold box.

The three air feed streams are all cooled in the cold box to cryogenic temperatures against returning product oxygen and nitrogen streams in plate-and-fin heat exchangers. The largest air stream is fed directly to the first distillation column to start the separation process. The second air stream is liquefied against boiling liquid oxygen before it is fed to the distillation columns. The smallest air stream is fed to a cryogenic expander to produce refrigeration for the cryogenic separation process. The work produced by the expander is used to power the turbine booster compressor.

The ASU produces oxygen product as a pressurized liquid which is then vaporized against the high-pressure hot air feed before being warmed to ambient temperature. All the oxygen is fed to a multi-stage intercooled centrifugal compressor. The compressed oxygen is fed to the gasification unit and a small amount is sent to the autothermal reformer in the F-T section and to the Claus plant. Nitrogen is produced at low and high pressures. A small amount of nitrogen is used as the regeneration gas for the pre-purifiers and is vented to the atmosphere.

Fischer-Tropsch Process

This process converts clean syngas to a total of 20,000 barrels of liquid hydrocarbon fuels per day. These product liquid fuels are gasoline and diesel. A Fischer-Tropsch slurry-bed reactor catalytically converts the sweet syngas into olefins by the following reaction:

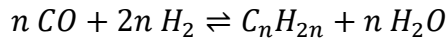

The catalyst for the above reaction is iron-based and it inherently produces hydrogen for the F-T synthesis by promoting the water-gas shift (WGS) reaction:

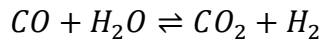

The process design aims at maximizing liquid production by recycling unconverted syngas in the exit gas from the F-T reactor after CO₂ removal. The light end F-T products are hydrotreated and stabilized while the heavy end F-T products are hydrocracked to reduce their pour point and produce commercial diesel fuel (U.S. Department of Energy, 1998).

The lighter hydrocarbons leave the slurry-bed reactor in their vapor phase, and they are cooled to collect the condensed liquid. The heavier hydrocarbons are removed in their liquid phases by separating them from the suspended catalyst, then cooled and then combined with the lighter products to make a precursor product to liquid fuel.

To enhance production, constant catalytic activity is ensured by continuous addition of fresh catalyst and withdrawal of used catalyst from the slurry-bed. The fresh catalyst is activated in a high temperature reducing atmosphere before re-addition to the reactor. The catalyst pretreatment equipment is like the slurry-bed reactor bar the internal cooling.

The clean syngas is mixed with steam and recycled gas and fed to the F-T synthesis reactor. The F-T reactor converts the hydrogen and carbon monoxide into straight chain olefins and aliphatic hydrocarbons, carbon dioxide and water. The exothermic reaction is cooled against water inside tubes within the slurry-bed reactor to generate 25 barg steam. Boiler feed water (BFW) is always made available for the cooling tubes and is circulated between the steam drum and the F-T reactor. The vapor stream from the reactor is cleaned of entrained catalyst particles and then cooled to about 4°C using four heat exchangers.

The CO₂ fraction of the vapor stream is captured by absorption using amine acid gas removal process. The captured CO₂ is released from the rich solvent, then compressed and dehydrated for transport and storage as explained previously. The CO₂ free vapor stream is dehydrated and compressed for recycle back to the F-T reactor.

The liquids from the top condenser are combined with the liquid hydrocarbons from the slurry-bed F-T reactor for upgrading. Entrained catalyst particles in the liquid stream are removed in a hydrocyclone. The bottoms of the hydrocyclone are withdrawn catalyst particles that are sent back to the F-T reactor.

The liquid from the cleaning hydrocyclone is expanded and then flashed. The resulting vapor stream is cooled down further to 35°C and then flashed. This splits the vapor stream to separate the light hydrocarbons (<C₄) that are to be used as fuel for the gas turbine. The tail vapor stream is combined with the CO₂ free vapor stream that is recycled back to the F-T reactor. This recycled gas passes through an autothermal reactor to convert the hydrocarbons into hydrogen-rich syngas before it enters the F-T reactor.

A portion of the vapor stream is split to recover hydrogen for hydrotreating purposes on the liquids. The liquids are split into three different streams: naphtha, distillate, and heavy wax streams. The recovered hydrogen hydrotreats naphtha and distillate streams and hydrocracks wax into naphtha and distillate fractions.

Ultimately, the liquid product contains 40% gasoline and 60% diesel. The top exit gases from the liquid production processes are fuels for the gas combustion turbines.

Combustion Turbine Generators

The combustion turbine generators are gas driven and produce a total of 132,500 kW of electric power.

Steam Generation

The secondary gasification zone produces raw gas at up to 1600°C and 40 barg. The raw gas stream is cooled to 350°C in a fire-tube boiler. The waste heat from raw gas cooling is converted to high-pressure steam. Outside the tubes is a saturated stream of boiler feed water whose water is separated in a steam drum. About 100 tonnes of saturated steam at 120 barg is produced from each gasifier. This steam is part of the heat recovery system to be supplied to the steam turbine.

The HRSG is a horizontal gas flow, drum-type, multi-pressure design consisting of a HP drum producing steam at the main steam pressure and an IP drum producing steam for export to the cold reheat. The steam circulation in the HRSG is naturally accomplished due to buoyancy differences of the steam. This transport mechanism provides a cost-effective and reliable design.

Flare Stack

A self-supporting, refractory-lined, carbon steel flare stack is fixed on each gasifier to burn and dispose product gas during startup, shutdown, and fault conditions.

The flare stack is equipped with multiple pilot burners that are fueled by natural gas or propane and have pilot monitoring instrumentation.

2.6.3 Major Equipment List

The major equipment list is found in the Appendix vii.

2.6.4 Capital Costs

The total plant cost estimates are based on costs that are reported in prior IGCC power plants and F-T liquid facilities that exist in the United States. The equipment costs are sourced from vendor-furnished cost data from different years. Appropriate index factors have been used to convert these costs to 2021 USD estimates. Material and construction labor costs estimates have also been factored by use of appropriate indexes to account for a typical location in Africa instead that is more relevant.

The Total Plant Cost includes cost for equipment, materials, labor, indirect construction, engineering, and contingencies.

- The “overnight construction cost” values are in terms of November 2021 USD.
- The costs for the gasification technology are estimates from past commercial price offerings found in literature (Bibber et al., 2007).
- The equipment cost index is CEPCI used to approximate equipment costs from previous years to the near present.

2.6.5 Operating and Maintenance Costs

Operation and maintenance costs are determined on a first-year basis followed by an analysis over a 30-year plant book life for the subsequent economic analysis. Quantities of the consumables such as process water, coal and chemicals have been obtained from heat and mass balance calculations. Table 7 summarizes the

part of the annual variable operating costs corresponding to the chemical consumables.

Other variables costs include maintenance costs, costs for operating and maintenance labor. It is assumed that maintenance costs are 4% of the total plant costs. Operating labour, maintenance labour and their corresponding annual costs are mentioned in more detail in Section 4.

Table 7: Consumable chemicals cost

Consumable chemicals	Consumption		Unit cost	Initial cost	Annual cost
	Initial	Daily			
MU & WT Chem. (tonnes)	51.1	7.2987	\$588	\$30 021	\$1 565 293
COS Catalyst (tonnes)	110.9	0.0610	\$2 814	\$312 169	\$62 636
Selexol solution (m ³)	755.8	0.1697	\$6 000	\$4 322 334	\$354 274
Zinc Oxide (tonnes)	110.9	0.0135	\$618	\$68 608	\$3 037
Total annual cost consumable chemicals				\$4 733 132	\$1 985 239

GCTL PROJECT Feasibility Report

Table 8: Summary of Total Plant Cost

Client: MAXIMUM ENERGY AND MINERALS LIMITED COMPANY				Plant size: 20,000 FT liq. bbl/day, 50 MW _e net			
Case: Coal Gasification for Fischer-Tropsch (No Refinery, No Sequestration)				Cost base: November 2021; \$×1000			
Acct No.	Item/Description	Equipment Cost	Material Cost	Labor		Bare Erected Cost (\$)	Eng'g CM H.O. & Fee
				Direct	Indirect		
1.	COAL & SORBENT HANDLING	17 601	3 109	9 857	690	31 257	2 501
2.	COAL-WATER SLURRY PREP & FEED	27 175	5 076	14 516	1 016	47 784	3 823
3.	FEEDWATER & MISC. BOP SYSTEMS	5 330	4 266	3 620	253	13 469	1 078
4.	GASIFIER & ACCESSORIES						
4.1.	Gasifier & Auxiliaries	117 307	47 403	62 691	4 388	231 789	18 543
4.2.	Syngas Cooling	w/4.1	w/4.1	w/4.1			
4.3.	ASU/Oxidant Compression	124 337		w/equip.		124 337	9 947
4.4.	Other Gasification Equipment	20 290	21 421	18 316	1 282	61 309	4 905
	Subtotal 4	261 934	68 824	81 007	5 671	417 435	33 395
5A.	GAS CLEANUP	71 315	6 996	47 409	3 319	129 038	10 323
5B.	FISCHER-TROPSCH SYSTEMS	141 520	17 893	11 080	776	171 269	13 702
6.	COMBUSTION TURBINE GENERATOR						
6.1.	Combustion turbine generator	30 122		685	48	30 855	2 468
6.2.	Accessories		162	108	8	278	22
	Subtotal 6	21 516	162	793	55	31 132	2 491
7.	HRSG, DUCTING & STACK						
7.1.	Heat Recovery Steam Generator	8 674		685	48	9 407	753
7.2.	HRSG Accessories, Ductwork and Stack	841	488	436	31	1 796	144
	Subtotal 7	9 515	488	1 121	78	11 202	896
8.	STEAM TURBINE GENERATOR						
8.1.	Steam TG & Accessories	19 594		1 690	118	21 403	1 712
8.2.	Turbine Plant Auxiliaries & Steam Piping	5 230	442	2 527	177	8 376	670
	Subtotal 8	24 824	442	4 217	295	29 779	2 382
9.	COOLING WATER SYSTEM	5 889	3 377	3 599	252	13 117	1 049
10.	ASH/SPENT SORBENT HANDLING SYS	20 447	9 780	12 514	876	43 618	3 489
11.	ACCESSORY ELECTRIC PLANT	5 567	2 280	4 359	305	12 511	1 001
12.	INSTRUMENTATION & CONTROL	8 615	1 198	4 498	315	14 626	1 170
13.	IMPROVEMENTS TO SITE	2 728	1 479	4 189	293	8 690	695
14.	BUILDINGS & STRUCTURES		3 299	4 050	283	7 633	611
15.	STORAGE FARMS						
15.1.	Storage farm Ludewa	15 000				15 000	1 200
15.2.	Storage Farm Makambako	15 000				15 000	1 200
	Subtotal 15	30 000				30 000	2 400
16.	TRUCK FLEET (200 Trucks)	20 000				20 000	1 600
TOTAL COST		\$673 977	\$128 670	\$206 828	\$14 478	\$1 032 559	\$82 605

3. Market Analysis

To analyze the market situation in Tanzania, a market analysis survey was prepared and personnel from Maximum Energy and Minerals Ltd facilitated acquiring required information. Data was collected from personnel and published reports of petroleum regulatory authorities such as EWURA, PBPA, and the Ministry of Energy. The findings of the market analysis are presented in this section.

3.1 Product Marketplace

3.1.1 Fuel Marketplace in Tanzania

The total fuel consumption for Tanzania is determined based on sales data obtained from wholesalers and Global Fluid International (GFI). As of the latest published EWURA annual report of 2020 (EWURA, 2020), the annual consumption of just diesel and gasoline averages about 59,000 bbl per day. This shows a 6.6% increase from 2019 which averaged about 55,000 bbl per day.

Table 9: Gasoline and Diesel consumption overview

Consumption	Gasoline/year	Diesel/ Year	Average consumption/day
2019	1,966,887,503 litres (12,371,350 bbl)	1,266,503,371 litres (7,966,067 bbl)	55,719 bbl/day
2020	2,014,652,962 litres (12,671,786 bbl)	1,432,829,462 litres (9,012,226 bbl)	59,408 bbl/day

The increase in consumption is evident through the increase in number of petrol stations for the years 2018-2020. There were 136 new petrol stations established in 2019 and 163 new petrol stations established in 2020 (EWURA, 2020). Figure 8 shows the number of petrol stations from 2018-2020 established in Tanzania.

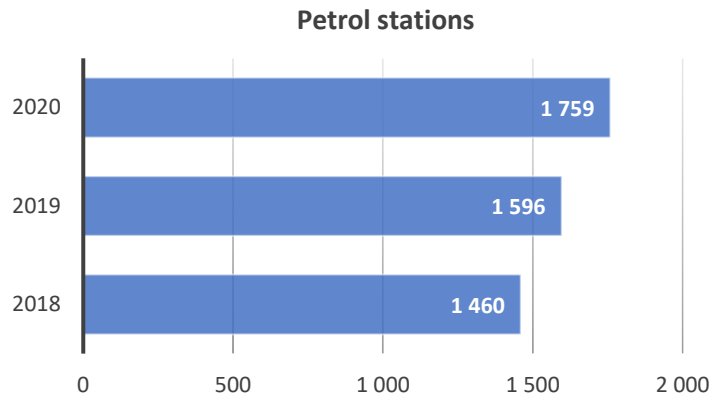

Figure 8: The total number of petrol stations in Tanzania between 2018 and 2020

Currently, 100% of fuel demand is covered by fuel importation through the Petroleum Bulk Procurement Agency (PBPA). This is in line with Section 168 of the Petroleum Act, 2015, Cap 392 which states that importation of petroleum products in the country must be conducted through an efficient procurement mechanism, as specified by the Minister responsible for Petroleum affairs. PBPA was developed to manage and coordinate importation of petroleum products. Currently petroleum products that are imported through Bulk Procurement System (BPS) are gasoline, diesel, Jet-A1 and Kerosene. The fuel market in Tanzania is currently occupied by 21 major suppliers. These are all registered with PBPA. The 2020 EWURA annual report (EWURA, 2020) shows a 10.5% increase in importation of gasoline and a 2.6% decrease in diesel fuel between 2019 and 2020.

Table 10: An overview of gasoline and diesel importation for 2019 and 2020

		2019 (in litres)	2020 (in litres)	Difference
Local imports	Gasoline	1,279,302,572	1,414,130,416	10.5%
	Diesel	2,021,033,634	1,969,238,830	-2.6%
	Total	3,300,336,206	3,383,369,246	2.5%

One of the roles of the authority (EWURA) is ensuring petroleum supply in the country meets the demand i.e., the country does not starve on key petroleum products that are essential for the economic wellbeing. Therefore, Petroleum wholesaler should maintain a physical operation stock in quantities of not less than 15 days requirement. For this reason, suppliers ensure they import more fuel than the demand and store the fuel in storage facilities. Most suppliers have their own storage facilities, but for suppliers who do not own such facilities can store their fuel under a hospitality agreement with depot owners. There are different sizes of storage facilities (tanks), but the minimum storage capacity (tank) is 2 million litres (12,580 bbl)

3.1.2 Fuel Pricing in Tanzania

In Tanzania, petroleum products prices are regulated by EWURA pursuant to the Petroleum Products Price setting Rules 2020 and the Petroleum Products Price Setting Rules 2009. EWURA sets and publishes cap prices applicable to all regions, district, and small townships monthly. The local pump prices or petroleum retail prices for all regions are computed based on the cost of discharge at Dar es Salaam, Tanga and Mtwara ports. It is an offence for operators of retail outlets (petrol stations) to sell petroleum products above cap prices in their respective areas. The Pricing Formula comprise the following elements: CIF costs, local

Government charges and levies, Government taxes, distribution costs and distribution margins. All these elements of the formula are fixed – except the CIF costs, which change depending on the prices of oil in the world market. This is in fact the single greatest contributor to changes of local pump prices.

The crude oil price is very unpredictable because it is governed by global changes. For example, the decrease of price from 2018 to 2019 was due to increase in oil production in the non-OPEC countries especially the US and because the demand was lower due to economic slowdown in China. Furthermore, the 32% decrease in crude oil price from 2019 to 2020 was due to COVID-19 pandemic and a price war between Russia and Saudi Arabia. Crude oil prices increased in 2021 as a global crude oil demand outpaced supply trading at an annual average of \$70.68/bbl (statista, 2022).

In 2022, we are already observing a blow out of crude oil price, and forecasts show that it will be higher than \$100 in the second quarter of 2022 (French, 2022). Currently Tanzania consumers would be experiencing a very high local pump prices if the government had not intervened and postponed collection of petroleum fee of TZS 100/litre on petrol, diesel and kerosene to reduce the cost of fuel to consumers (EWURA, 2022). From Figure 9 and Figure 10, it is apparent how the fluctuations of crude oil in the world market affects the local pump prices.

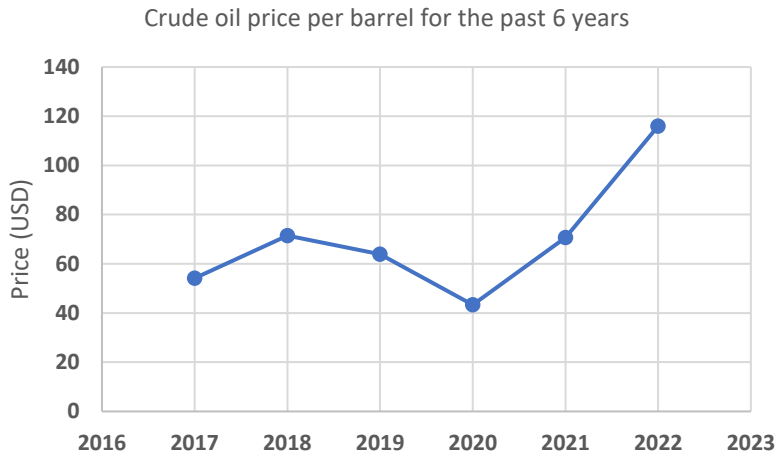

Figure 9: Crude oil price from 2017 to 2020

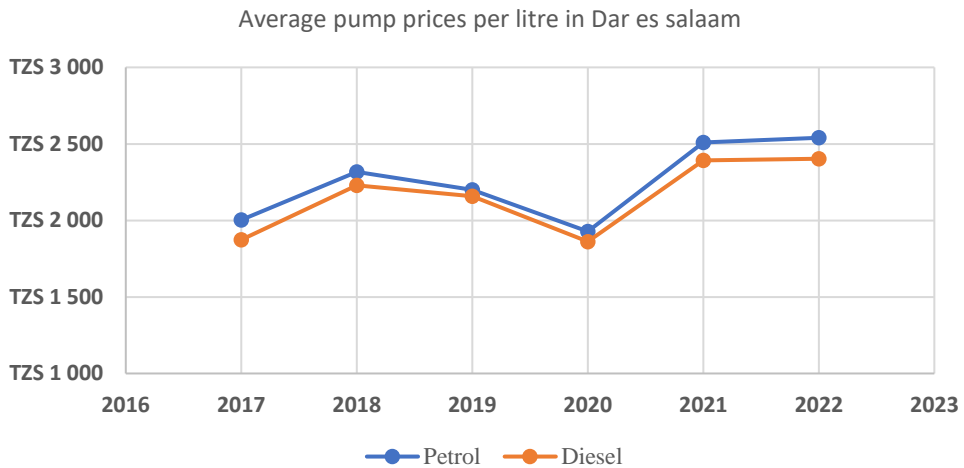

Figure 10: Average pump prices per litre for gasoline and diesel from 2017 to 2020

The sole dependence on importation affects not only the importers and distributors/suppliers of fuel, but also the end users significantly through continuous price fluctuations. Early 2022, the government was losing

revenue to manage the extreme rise of fuel pump price. This gives an indication that it is difficult to completely win the fight with global trends. It would be beneficial for both the government and the fuel users if as a country we minimize the dependence on importation by developing our own fuel production initiatives in Tanzania. Maximum Energy and Minerals Ltd aims to be the first contributor to such initiatives by constructing the first Green Coal to Liquids (CTL) plant in Tanzania. The CTL plant at Ludewa is expected to produce 20,000 bbl/day of fuel (8,000 bbl/day of gasoline and 12,000 bbl/day of diesel), hence minimizing the dependence on importation by an estimate of 34% based on the total consumption of 2020 (EWURA, 2020).

Expected distribution between Imports and the planned CTL Plant

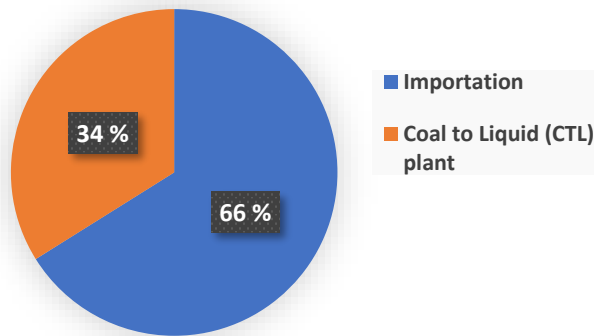

Figure 11: Expected distribution between gasoline and diesel imports and the planned CTL Plant

3.1.3 Sulphur Marketplace in Tanzania

In addition to the fuel produced at the plant, 87 tonnes/day of Sulphur will also be generated from the process. This amounts to 31,755 tonnes/year which can be

sold and used domestically in Tanzania or exported depending on the market demands.

Tanzania became the 41st largest importer of Sulphur in the world in 2020 after importing a total of \$6.55M in Sulphur. During the same year, Sulphur was the 278th most imported product in Tanzania. Tanzania imports Sulphur primarily from Turkey, Saudi Arabia, Italy, Spain and India. The main destination of Sulphur exports from Tanzania is Democratic Republic of the Congo (\$18.4k) (OEC, 2020).

There are currently 5 importers of Sulphur in Tanzania. These are Shell, Indian Oil Corp. Ltd, Valero Energy Corporation, Motiva Enterprise, and Exxon Mobile (Abdallah, 2022). This is a good indication of the market availability for Sulphur in Tanzania.

Sulphur is used in Agrochemical manufacturing companies to provide protection and treatment of crops. Sulphur is important in agriculture as it has been proven that Sulphur-containing agrochemicals increases growth, yield and protein in the crops (Burkitbayev et al., 2021). Sulphur combats fungal diseases that affect crops such as brown rot, scab, mildew, powdery mildew, leafspot and rusts, and is also used for postharvest disease control (Gammon et al., 2010).

The consumption of fertilizers in Tanzania in 2018 was 15.858 kg per hectare of arable land (TanzaniaInvest, 2022). There are many distributors of agrochemical and fertilizer in Tanzania as over 90% of fertilizer used in Tanzania is imported. However, due to the high need of fertilizers, the import costs result in high retail prices which inhibits access to fertilizers by small-scale farmers (TanzaniaInvest, 2022). This challenge in pricing can be addressed by producing more fertilizer domestically. The fertilizer manufacturing companies in Tanzania that are potential

market for Sulphur produced at Ludewa include Minjingu Mines and fertilizer and Tanzania fertilizer company Ltd.

3.1.4 Sulphur Prices in Tanzania

There appears to be no big difference between the granular and the lump Sulphur, but in all instances, it is the granular type that is sold at a higher price than lump type. The average price of Sulphur has been fluctuating for the past 5 years with the average lowest price in 2020 at \$117 granular Sulphur and \$107 lump Sulphur and highest average price by March 2022 at \$400 granular and \$390 lump Sulphur (Abdallah, 2022) as shown on Figure 12 below.

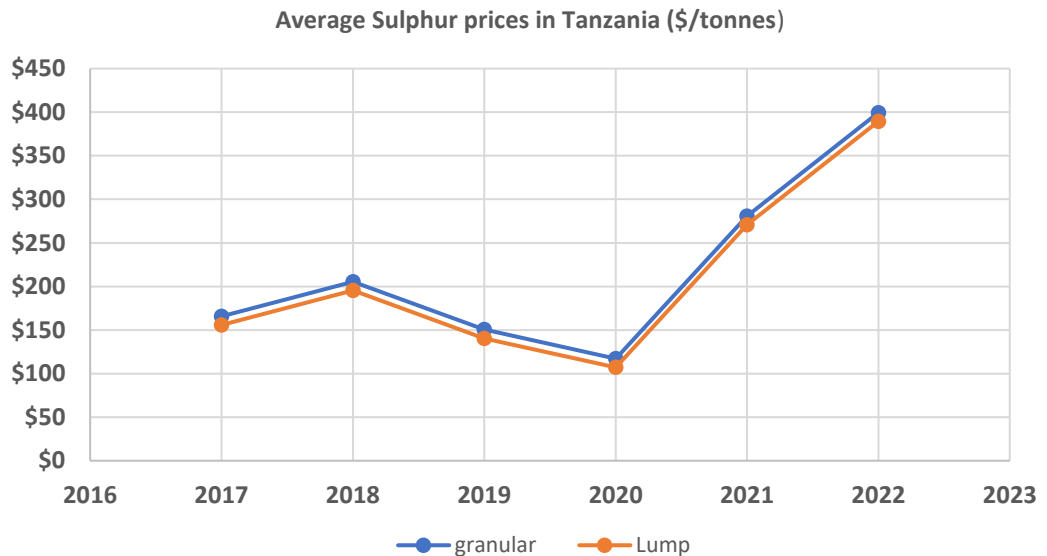

Figure 12: Average Sulphur prices in Tanzania

3.2 Marketing Strategy

We have identified the expected market for the products from the Green CTL plant as shown on Table 11 below:

Table 11: Expected marketplace of the Green CTL plant products

Products	Expected market
Main products	
Fuel (Diesel and Gasoline)	<ul style="list-style-type: none"> • Phase I: 100% Local/ domestic market • Phase II: Possibility of extending the market to neighboring countries
Electricity	<ul style="list-style-type: none"> • Market planned for sale locally in Tanzania • Possibility to sell to Malawi • Supply to local villagers for free
Other products	
Sulphur	<ul style="list-style-type: none"> • Plan to export to China, Turkey, or India – Primary market • Local/domestic use in agrochemical manufacturing companies - Secondary market
Tar	<ul style="list-style-type: none"> • Local/domestic market – Can be used as a construction material for example in residential homes as an alternative to pavement blocks • Plan to use to support plant operations: <ol style="list-style-type: none"> i. Road maintenance in Ludewa ii. Construction of playgrounds in the village i.e., football grounds, basketball grounds etc. iii. Construction of gardens around the employee accommodation areas.

To facilitate achieving sufficient sales to cover the return on investment (ROI) and a favorable profit margin from the main product (gasoline and diesel), Maximum Energy and Minerals Ltd. will adopt the following marketing strategy.

3.2.1 Pricing Strategy

Provided that fuel will be produced locally, it will not be affected by global trends. MEML will manage operating costs so that fuel can be sold at a lower price than suppliers in Tanzania pay to import. The price of fuel will be determined by the cost-plus strategy. The price of fuel will be set depending on the costs incurred and an additional profit margin added. The price of Sulphur will be set based on

competitor market and the market demand. The price of tar will be set to be affordable to attract customers to adopt it as an alternative to paving blocks.

3.2.2 Location

Fuel orders will be managed at the main offices in Dar es salaam. In the first phase, fuel suppliers will have to collect fuel from the storage farm in Makambako. In the next phases, the company will add storage facilities in big cities.

3.2.3 Promotion

Since this is the first time such process is being done in Tanzania, MEML will set various strategies to bring awareness on the process. Marketing visits to suppliers will be conducted to bring awareness of our product. MEML will ensure to show that the process adheres to environmental sustainability and is conducted in a green manner.

Promotions will be done to bring awareness of other products i.e., Sulphur and tar and how tar can be adopted as a construction material. The promotions will be done via public interviews, press conferences, exhibitions at Sabasaba grounds, publishing on the company website, banners, and other paid media advertisements.

3.2.4 People

The plant will have few expats and locals at the beginning but is expected to be run by locals 100% after completion of technology and knowledge transfer. Training camps will be established at the plant site during construction to build competency of the employed technical staff so they can be ready to work as soon as the plan begins operations. MEML will provide continuous trainings to its employees to ensure and maintain a high-quality process.

These operations will stimulate other indirect effects i.e., opportunities for growth of private and small businesses including but not limited to catering services, laundry services, cleaning services, transport services etc.

There are plans to link universities and the plant through provision of PT or field positions, research opportunities (data collection). Furthermore, MEML will set a \$2.5 cost/barrel and invest in research, development, and innovation (RDI) activities aiming at making coal operations greener i.e., carbon capture solutions.

3.2.5 Physical Facilities

To facilitate the operation at the plant and sales of the product, the company will have the following facilities.

- A main office in Dar es salaam
- Two storage farms in Makambako and Ludewa
- The plant at Ludewa where the fuel will be produced
- A fleet of 200 trucks to ensure daily fuel transport to Makambako
- A hospital where villagers and employees will get medical assistance
- Free electricity supply to the nearby villagers
- Accommodation facilities for employees working at the plant

3.2.6 Process

MEML will make the selling and buying process convenient for customers through investing in a fleet of trucks to eliminate the transport challenges that could otherwise be incurred by customers. MEML will ensure that fuel is transported on daily basis from Ludewa to Makambako storage farm where customers will be able to easily access it.

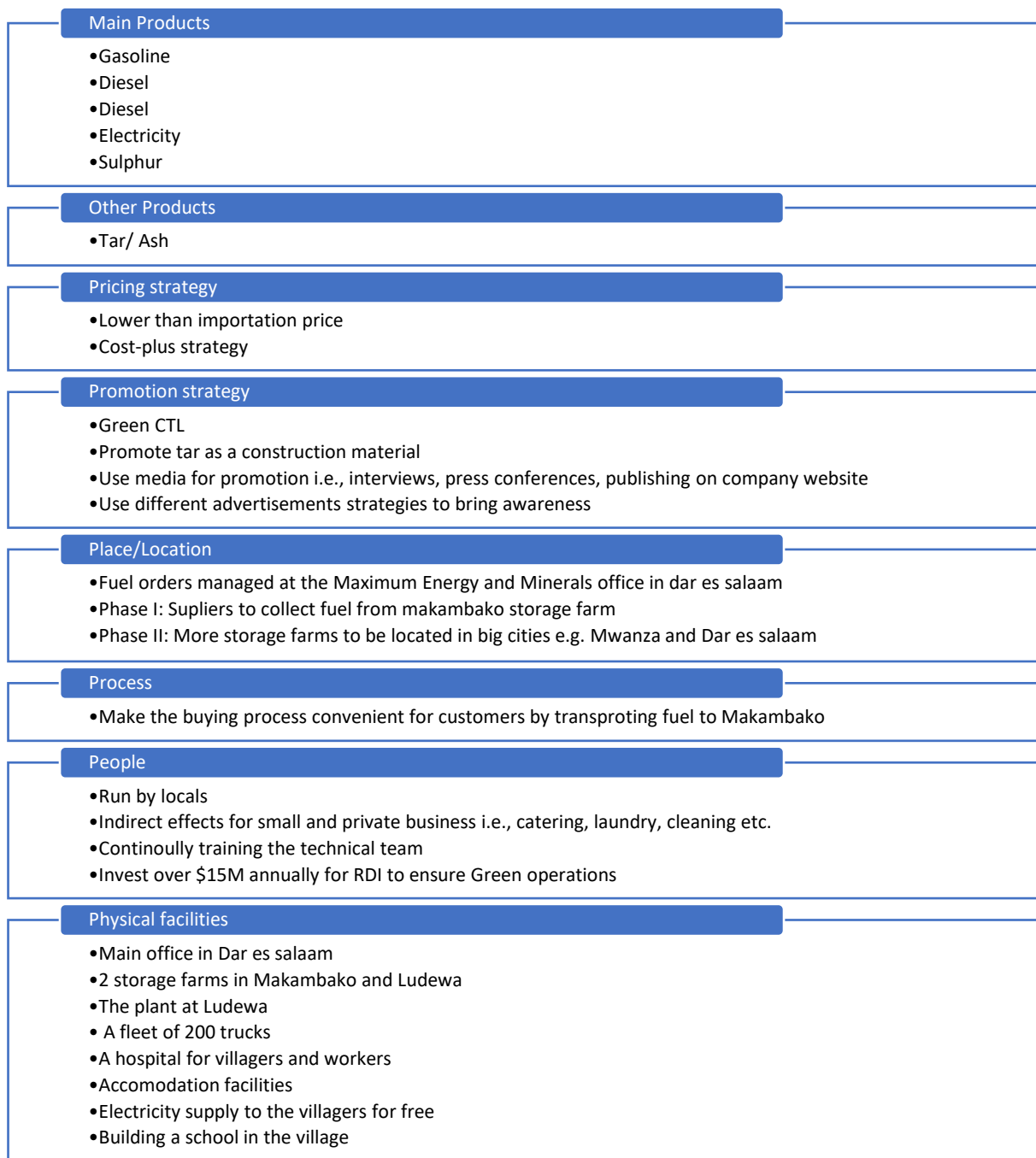

Figure 13: Summary of the marketing strategy

4. Organization/Staffing

This project is expected to be run by Maximum Energy and Minerals Limited which is one of the companies belonging in the Maximum Group of Companies. Maximum Energy and Minerals manages three types of operations under three different companies namely Maxcoal Ludewa, Maximum Cement Ltd and Maximum Renewables. The Green CTL plant will be operated by Maxcoal Ludewa together with the Coal mine operations, management of fuel storage farms in Makambako and Ludewa and the management of all types of logistics to support the CTL plant. This structure is presented in Figure 14 below.

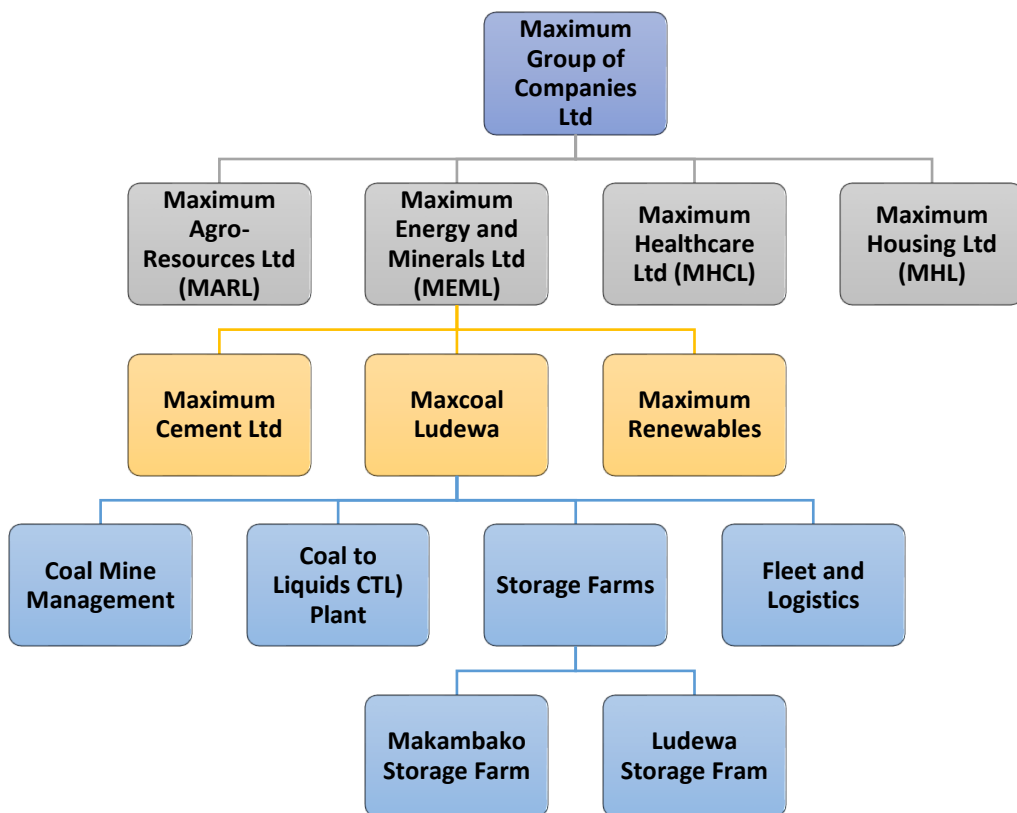

Figure 14: Maximum Group of Companies organization structure

During the operation phase, the number of organization of staffing/personnel positions that will need to be covered are expected to be as shown on Table 12. The CTL unit operating labour cost per month includes costs of health insurance, meals, accommodation at the plant and transport to and from the plant every rotation.

Table 12: Operating labour requirements for the project

CTL Operating labour		
	1 unit	Total
Skilled Operator	4	8
Operator	20	40
Foreman	4	8
Lab Technician etc.	8	16
HSE	1	2
Storage facilities	5	10
Plant manager		1
Superintendent		1
Total per shift		86
Total (all 2 shifts)		172
Mining and other labour		
		Total
Drivers and assistants		700
Security		25
Housekeeping		25
Catering		15
Mining Operations		300
Truck mechanics (workshop)		100
Sales, marketing, and distribution		200
Total		1,365
Total labour		1,537

5. Schedule

The feasibility study is estimated to take 2 months, followed by the regulatory framework which is also estimated to take 2 months. The contractor selection process is estimated to take 1 month followed by FEED which is estimated to take a total of 5 months. The construction phase is estimated to take 3 years followed by 1 year of testing and commissioning. The plant life is estimated to be 30 years and the company plans to take green initiatives from the first year of operations so the plant can achieve a CO₂ net zero 5 years after operation starts. The timeline for the CTL plant is presented on Figure 15 below.

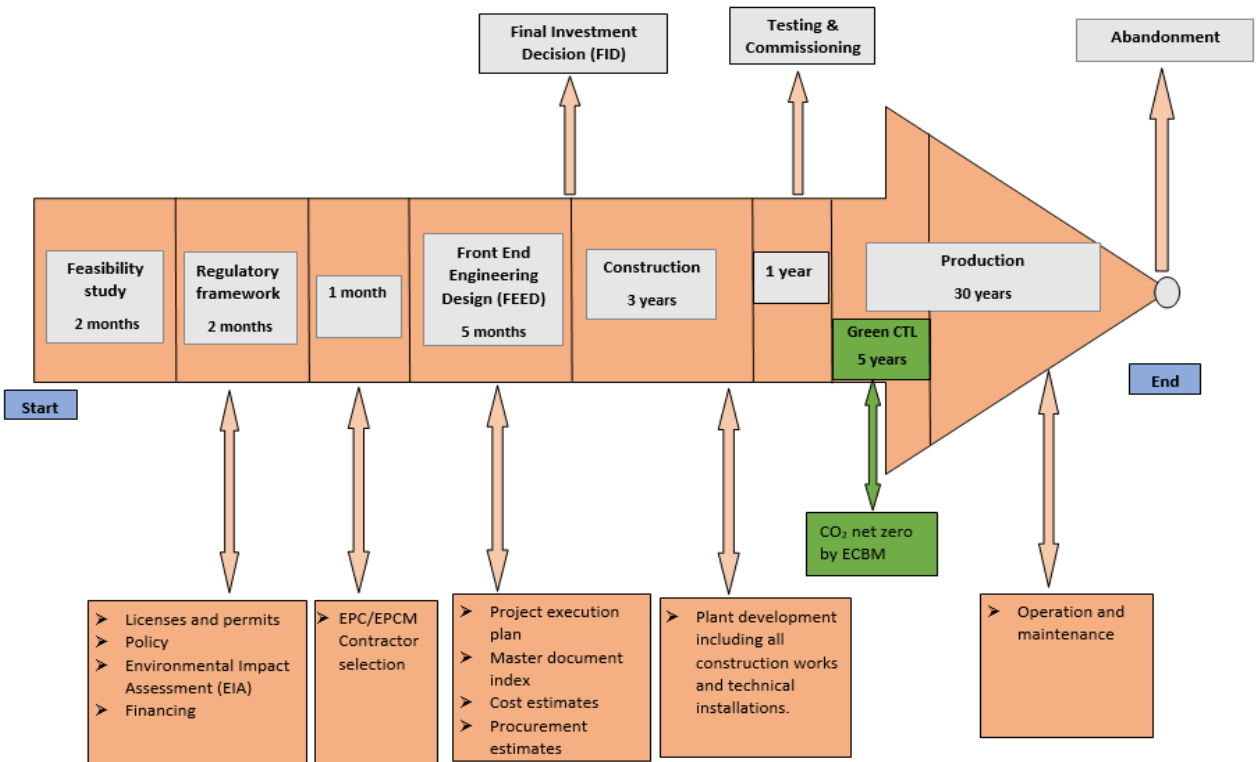

Figure 15: Estimated CTL Plant Project timeline

6. Financial Projections

6.1 Financial Analysis

For the financial analysis, the results of the Green Coal to Liquids (CTL) plant design and cost estimates presented in Section 2 of this report (Technology Consideration) were used. This analysis presents the overall economics of the plant by considering the cash inflows and outflows of the major product outputs. Figure 16 below depicts a simplified schematic of the inputs and outputs of the plant which this financial analysis has considered.

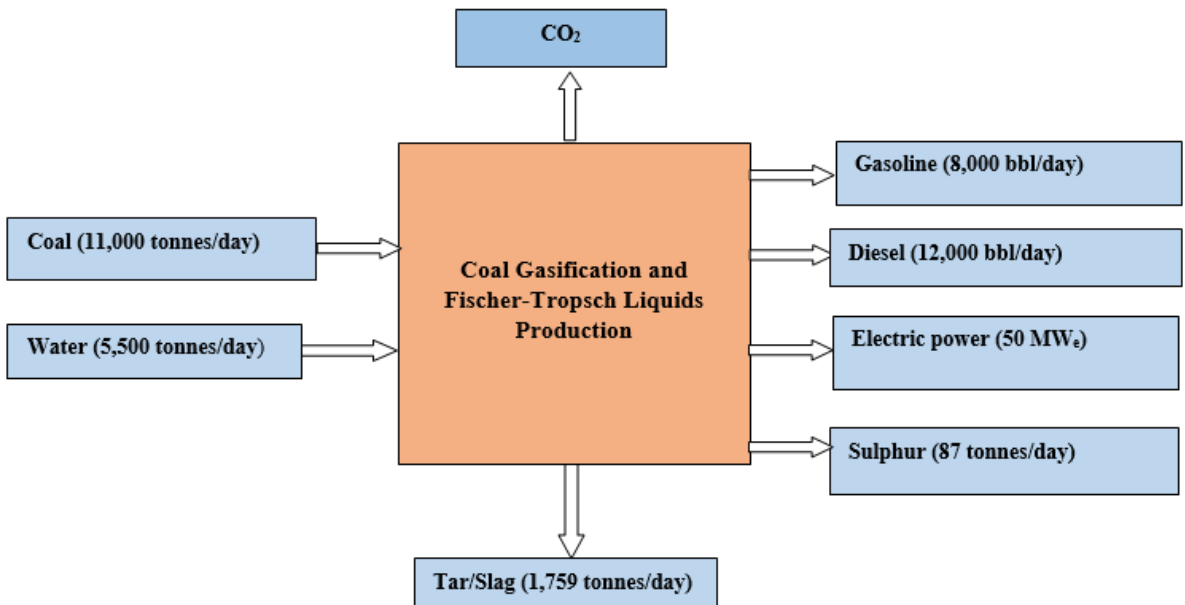

Figure 16: Major Inputs and outputs of Green Coal to Liquid Plant project with nominal 20,000 bbl/day

The key results of this analysis are the return on investment (ROI), the net present value (NPV) and the pay back price (PBP). Various sources were consulted in

development of appropriate financial assumptions i.e., EWURA published reports and the EIA report conducted for the plant, Petroleum Acts, PBPA reports and other readily available published data.

The major assumptions made include:

- 100% plant availability
- 30% tax rate
- 30-year plant life
- 13% discount rate
- 6 years pay-back period
- 85:15 debt to equity ratio
- Loan to be fully repaid in 10 years.
- Only loan interest will be paid for the first 4 years – during construction and testing & commissioning phases
- For depreciation calculation, a straight-line method was used, and it was assumed that the salvage value of the plant and equipment would be 80% of the purchase price.
- ***For the sale of fuel (gasoline and diesel)***
 - a) \$100 price per barrel equivalent to \$0.63 per litre. This price was selected based on the current price of crude oil as of March 2022 (French, 2022).
- ***For the sale of Sulphur***
 - a) Price of Sulphur used for calculation is \$200 per tonne. Due to major fluctuations of price of Sulphur in the past 6 years, the price was selected by finding the average price from 2017-2022.

- **For the sale of electricity**
 - a) Price considered for sale of electricity was \$0.4/unit

Table 13 below summarizes the results of the financial analysis under baseline financial conditions.

Table 13: Financial Analysis Results

Major Inputs (In thousand dollars)	
Total EPC cost (\$)	1,479,199
Production (bbl/day)	20,000
Coal (tonnes/day)	11,000
Major results	
ROI (%)	30%
NPV (\$100, 13%)	\$ 513,155
Break-even price at 6 years payback period (\$/bbl)	\$ 45.35

The base case shows positive financial performance, with a 30% return on investment (ROI) and a net present value of over \$513 million.

6.2 Performance and Cost Sensitivities

Some inputs were selected for sensitivity analysis to see how a +/-25% change would impact the NPV and ROI. The inputs varied were the interest rate on the loan, the plant, storage farms and truck fleet cost, the project life, the income tax rate and the depreciation rate of the equipment and property. After varying the inputs, the lowest and highest ranges were found to be as presented on Table 14. Figure 17 shows the variations in ROI using the +/-25% variation in the financial analysis.

Table 14: Values used in sensitivity analysis (in thousand dollars)

Cost varied	Base case	(+25%) High Range	(-25%) Low Range
Plant, storage farm and fleet cost (\$)	1,115,164	1,393,955	836,373
Project life (years)	30	38	23
Loan interest rate (%)	4	5	3
Depreciation (\$)	12,548	15,685	9,411
Income tax rate (%)	30	38	23

Changes in ROI for selected inputs (+/- 25%)

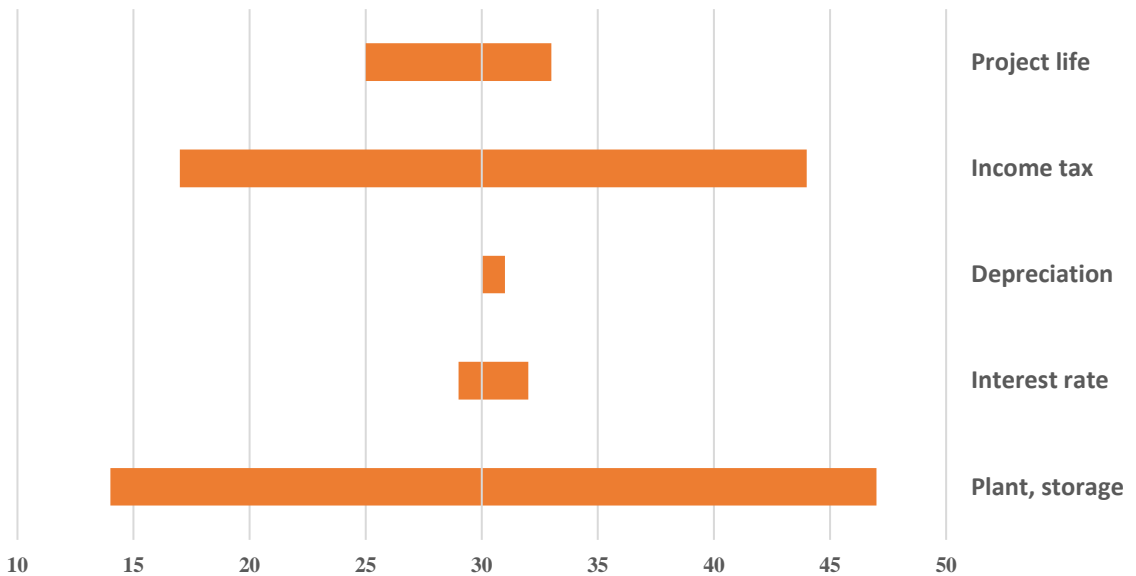

Figure 17: Changes in ROI with +/-25% change in selected inputs

Overall, only two of the five selected inputs for the sensitivity analysis (income tax and plant, storage farm and fleet cost) were found to have a significant impact on the ROI. But even with these significant changes, the project still shows a high return. The analysis shows that a 25% increase in the plant, storage farms and fleet

cost will lower the ROI by 53% while a decrease of 25% will increase the ROI by 57%. On the other hand, a 25% increase in the income tax rate will decrease the ROI by 43% while a 25% decrease will increase the ROI by 47%. A 25% change in the loan interest rate was found to not have a significant impact on the ROI. A 25% increase in interest rate will only lower the ROI by 3% while a 25% decrease will increase the ROI by 7%. A decrease in the depreciation rate by 25% will only add 3% to the ROI while an increase in the depreciation rate by 25% will not have any effect on the ROI. As for the project life, a 25% decrease of project life will decrease the ROI by 17% while a 25% increase will result in a 10% increase in the ROI.

In general, the project finance inputs selected for sensitivity analysis appear to be robust even with up to a 25% change in several of the outputs subject to change. Even with the changes observed, the project returns are still positively significant with the lowest NPV of \$234,364,000 and highest NPV of \$791,946,400 both because of a 25% change of the plant, storage farms and fleet costs as shown on Figure 18.

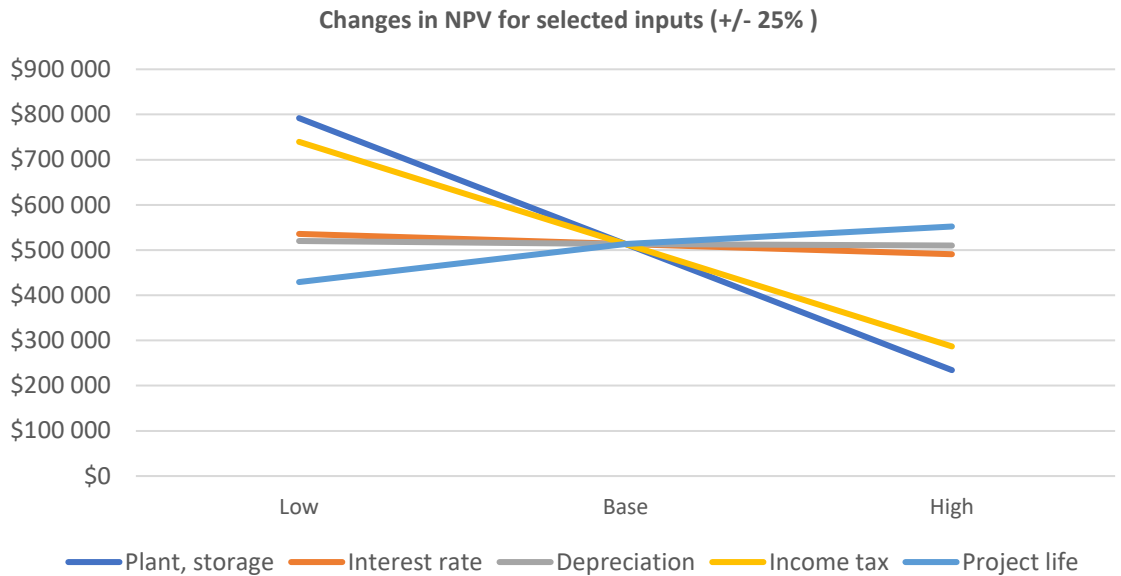

Figure 18: Changes in NPV with +/-25% change in selected inputs

6.3 Projected Income Statement

The projected income statement for the first year is presented in

Table 15 below. Assumptions made include:

- Straight line depreciation
- 100% plant availability
- All products produced are sold (Fuel, Sulphur, and electricity)
- Maintenance cost is set higher and assumed constant. Provided that all plant equipment will be new, they will require less maintenance than expected hence the amount will be sufficient.

Table 15: Projected Income Statement for Year 1

Projected Income Statement			
Maximum Energy and Minerals Ltd			
Launch of CTL Ludewa plant			
	Year 1	Year 2	Year 3
Revenues			
Fuel	\$730 000 000	\$730 000 000	\$730 000 000
Electricity	\$18 250 000	\$18 250 000	\$18 250 000
Sulphur	\$6 351 000	\$6 351 000	\$6 351 000
Total sales	\$754 601 000	\$754 601 000	\$754 601 000
Cost of sales (COGS)	\$75 110 240	\$75 110 240	\$75 110 240
Gross profit	\$679 490 760	\$679 490 760	\$679 490 760
Expenses			
Maintenance cost	\$44 606 560	\$44 606 560	\$44 606 560
Admin and support staff cost	\$175 565 000	\$175 565 000	\$175 565 000
Green CTL cost	\$14 400 000	\$14 400 000	\$14 400 000
Depreciation	\$12 548 533	\$12 548 533	\$12 548 533
Interest	\$50 292 766	\$41 910 638	\$33 528 511
Total Expenses	\$297 412 859	\$289 030 732	\$280 648 604
Pre-Tax Earnings	\$382 077 901	\$390 460 028	\$398 842 156
Income tax provision (30%)	\$114 623 370	\$117 138 009	\$119 652 647
Earnings after tax	\$267 454 530	\$273 322 020	\$279 189 509

6.4 Statement of Cash Flow

The statement of cash flow for the first year is presented in Table 16 below.

Assumptions made include:

- Sales for fuel are 100% received while sales for Sulphur and electricity are receivables
- 50% of COGS is paid while 50% is payable
- In expenses, maintenance and support staff cost are 100% paid while Green CTL cost is 100% payable
- 80% of income tax is paid while 20% is payable.

Table 16: Statement of cash flow for Year 1

Maximum Energy and Minerals Ltd	
Statement of Cashflow Year 1	
Cash In	
Loan received	\$1 257 319 150
Paid Up capital	\$435 994 106
Sales	\$730 000 000
Total Cash In	\$2 423 313 256
Cash Out	
COGS paid	\$37 555 120
Expenses paid	\$220 171 560
Tax Paid	\$91 698 696
Truck fleet purchased	\$370 000
Interest	\$50 292 766
Loan repayment	\$209 553 192
Capex	\$1 479 199 000
Total Cash Out	\$2 088 840 334
Cash balance	\$334 472 922

6.5 Balance Sheet

The balance sheet for year 1 is presented in Table 17 below showing a profit of \$267,454,530 at the end of year 1.

Table 17: Balance sheet for Year 1

BALANCE SHEET FOR YEAR 1			
Maximum Energy and Minerals			
CTL Ludewa Project			
ASSETS		LIABILITIES	
Current			
Cash and cash equivalents	\$334 472 922	Current liabilities	\$74 879 794
Receivables	\$24 601 000	Long-term liabilities	\$1 047 765 958
Total current assets	\$359 073 922	Total liabilities	\$1 122 645 752
Non-Current		Equity	
Capex (project)	\$1 467 020 466	Owner's capital	\$435 994 106
		Profit for the year	\$267 454 530
Total non-current assets	\$1 467 020 466		
Total assets	\$1 826 094 388	Total Liabilities and equity	\$1 826 094 388

7. Findings and Recommendations

7.1 Technology

There are enough coal reserves for the current CTL plant capacity and even for future expansion. CO₂ injection in deeper coal seam layers for enhanced coal bed methane production will also be considered. The produced water will be cleaned and used in the closed cycle CTL plant.

Production of liquid fuels from coal is done indirectly by using entrained flow gasification technology followed by a Fischer-Tropsch synthesis loop to convert the clean syngas from gasification plant into commercial grade diesel and gasoline. Waste heat from gasifiers, and the F-T reactors is collected and used to generate electricity using a heat recovery steam generator. In addition, tail gas is burnt in gas turbines to produce more electric power. Other by-products of the facility are sulphur that can be sold, and ash/tar that can be used for construction.

The plant design concept includes two gasification plants located on two ends of the facility area and a central plant that collects the syngas and process it for liquid fuel production. A large fraction of equipment cost is for the gasification systems and their accessories. Plant design predicts a significant amount of electric power load required especially in ASUs and O₂ compression, and fuel gas compression. However, electric power produced from HRSG, and gas turbines caters for this leaving a positive net power of about 50 MW_e.

7.2 Marketing

Comparing the daily consumption of gasoline and diesel in Tanzania with the annual planned production at CTL plant, there appears to be sufficient market for gasoline and diesel. The demand for gasoline and diesel is high and with the

unexpected global trends impacting crude oil prices, the CTL plant will offer a competitive solution with gasoline and diesel prices not impacted by global trends.

The 50MW_e of electricity expected to be produced by the plant will provide a favourable solution to the local villagers promoting the development of various businesses and growth of the village and district at large. Furthermore, Maximum Energy and Minerals Ltd can benefit by an estimate of \$18,250,000 annually from the sale of electricity to domestic or international market i.e., Malawi which is a neighbouring country and located very close to the plant.

In 2020, Tanzania imported \$6.55M of Sulphur making it the 41st largest importer of Sulphur. With the plant estimated to produce 31,755 tonnes/year of Sulphur from its operations, there is a big potential for market both domestically for use in agrochemical manufacturing companies and internationally for export. Maximum Energy and Minerals Ltd can benefit from the Sulphur by an estimate of \$6,351,000 annually.

In addition, 1,759 tonnes/day of tar will be produced from the plant operations. There is potential for market if Maximum Energy and Minerals Ltd promotes tar as a construction material in residential homes as an alternative to pavement blocks. Furthermore, tar will be utilized for road maintenance operations and construction of playgrounds in the village and gardens in the plant accommodation area.

7.3 Organization

The planned CTL plant will have both direct and indirect benefits to the citizens of Tanzania. A total of about 1,537 people will be working directly for the plant including those with permanent employment, temporary employment, service providers such as housekeeping, security, catering etc. Furthermore, the multiplier effect will be seen in all other business areas impacting positively the economic

development individual citizens and the country at large. Due to increase in movement to and from Ludewa, it is expected that hotel business will grow, transport needs will increase, the need for houses for rent will increase due to increase on number of people at Ludewa. Small businesses i.e., shops, restaurants, fresh produces will develop impacting the lives of villagers. Maximum Energy and Minerals will also engage in several CSR activities including building a health care facility and school that will benefit the villagers directly.

7.4 Financial

The CTL plant shows very positive financial projections with very high returns (ROI = 30%, NPV = \$513,155,000). Furthermore, a sensitivity analysis was conducted by varying the project plant, storage farms and fleet costs, income tax rate, project life, interest rate and depreciation rate by 25%. The results showed that the income tax rate and the plant, storage farms and fleet costs were the most sensitive inputs. But overall, the sensitivity analysis showed that financial projections appear to be robust with lowest ROI of 14% and highest 47%. The CTL plant is a very attractive investment to both investors and the rest of the Tanzanians who will be highly impacted in a positive manner through this project endeavor.

7.5 Recommendations

The planed CTL plant will serve the country's energy security issues and reduce dependance on importation of liquid fuels, in this setting and considering Tanzania's fuel market, the plant is strongly profitable. Utilization of modern and advanced technologies, the motive of the owners and planned environmental impact mitigation measures makes the plant environmentally friendly. We would like to highly recommend implementation of this project.

References

- Abdallah, A. (2022). *Sulfur Price in Tanzania*. Retrieved March 2022 from <https://sulfur-price.com/today/tanzania>
- Bibber, L. V., Shuster, E., Haslbeck, J., Rutkowski, M., Olson, S., & Kramer, S. (2007). *Baseline technical and economic assessment of a commercial scale Fischer-Tropsch liquids facility*.
- Buluma, G., & Ndonde, R. (2021). *Technical Report for Maxcoal-Ludewa Property, Southern Tanzania*.
- Burkitbayev, M., Bachilova, N., Kurmanbayeva, M., Tolenova, K., Yerezhopova, N., Zhumagul, M., Mamurova, A., Turysbek, B., & Demeu, G. (2021). Effect of sulfur-containing agrochemicals on growth, yield, and protein content of soybeans (*Glycine max* (L.) Merr). *Saudi journal of biological sciences*, 28(1), 891-900. <https://doi.org/10.1016/j.sjbs.2020.11.033>
- David Coil; Erin McKittrick; Bretwood Higman. (2012, 25th September 2012). *Coal Terminology: Resource & Reserve*. Retrieved March 2022 from <http://www.groundtruthtrekking.org/Issues/AlaskaCoal/CoalTerminology.html>
- EWURA. (2020). *The-Mid-and-Downstream-Petroleum-Subsector-Performance-Review-Report-FY-2020*. EWURA
- EWURA. (2022). *Public notice on cap prices for petroleum products effective wednesday, 2nd March 2022*. EWURA
- French, M. (2022). *EIA expects crude oil prices higher than \$100 per barrel in coming months*. U.S. Energy Information Administration. Retrieved 30-March-2022 from <https://www.eia.gov/todayinenergy/detail.php?id=51658>
- Gammon, D. W., Moore, T. B., & O'Malley, M. A. (2010). Chapter 88 - A Toxicological Assessment of Sulfur as a Pesticide. In R. Krieger (Ed.), *Hayes' Handbook of Pesticide Toxicology (Third Edition)* (pp. 1889-1901). Academic Press. <https://doi.org/https://doi.org/10.1016/B978-0-12-374367-1.00088-4>
- Hillestad, M., Ostadi, M., Alamo Serrano, G. d., Rytter, E., Austbø, B., Pharoah, J. G., & Burheim, O. S. (2018). Improving carbon efficiency and profitability of

the biomass to liquid process with hydrogen from renewable power. Fuel, 234, 1431–1451. <https://doi.org/10.1016/j.fuel.2018.08.004>

Global_CCS_Institute. (2021). *Global status of CCS 2021*.

IPCC. (2005). *IPCC Special Report on Carbon Dioxide Capture and Storage*.

OEC. (2020). *Sulphur in Tanzania*. <https://oec.world/en/profile/bilateral-product/sulphur/reporter/tza>

Sasol Petroleum International. (2005). *SASOL'S SECUNDA CTL PLANT: COSTLY TO BUILD, BUT NOW IT'S A CASH COW*. Retrieved 30 April from <https://web.archive.org/web/20110215091445/http://www.highbeam.com/doc/1P3-793476071.html>

statista. (2022). *Average annual Brent crude oil price from 1976 to 2022*. Retrieved 28-March-2022 from <https://www.statista.com/statistics/262860/uk-brent-crude-oil-price-changes-since-1976/>

TanzaniaInvest. (2022). *Fertilizers*. TanzaniaInvest.

U.S. Department of Energy (1998). *BASELINE DESIGN/ECONOMICS FOR ADVANCED FISCHER-TROPSCH TECHNOLOGY* (DE-AC22-91PC90027-01).. Federal Energy Technology Center Morgantown (FETC-MGN), Morgantown, WV (United States); Federal Energy Technology Center Pittsburgh (FETC-PGH), Pittsburgh, PA (United States). <https://doi.org/10.2172/14176>

Appendices

Appendix i: Proximate, GCV and Ultimate Analysis of Coal Sample

1. Proximate, GCV and Ultimate Analysis of Coal Sample

SN	SAMPLE PARTICULARS	SAMPLE NO	ON AIR DRIED BASIS (AD)					GCV Kcal/Kg	ULTIMATE ANALYSIS (AD)		
			PROXIMATE ANALYSIS				Ash %		C %	H %	S %
			M %	VM %	FC %	FC %					
2	Sample 01	IRD/RD/21/64	15.99	1	32.34	50.67	6742	76.79	4.74	1.56	

Key: M - Moisture, VM - Volatile Matter, FC - Fixed Carbon, GCV - Gross Calorific Value, C - Carbon, H - Hydrogen, S - Sulphur

Tested by: Kenan J-7 Signature: 

Approved by: Hoosen Iddi Signature: 

DIRECTOR GENERAL
 State Industrial Research & Dev. Organisation
 P. O. Box 2323
 Addis Ababa

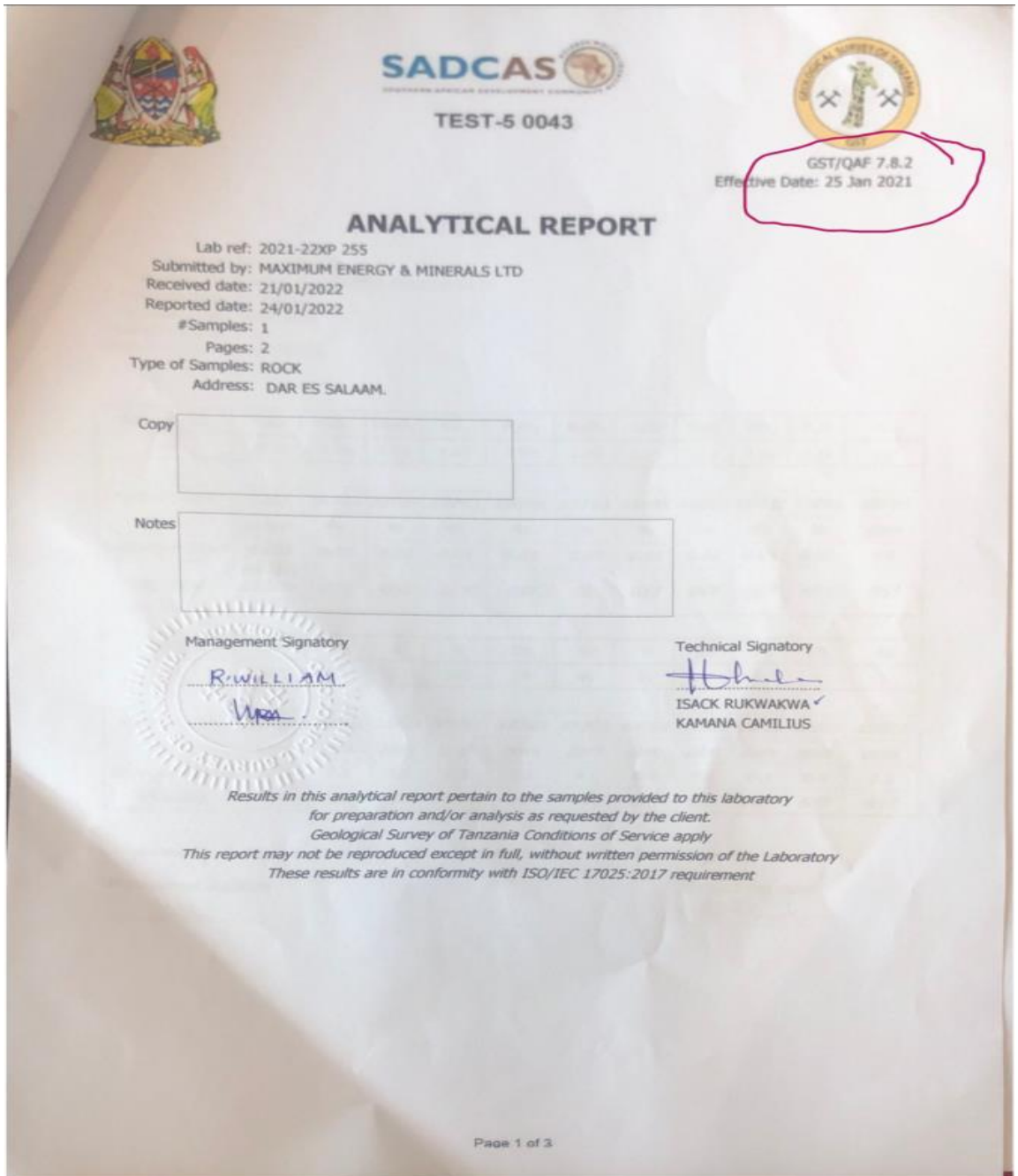

The image shows a document titled "ANALYTICAL REPORT" from SADCAS (SADC APPLIED CHEMISTRY LABORATORY). The document includes a header with the SADCAS logo and the text "TEST-5 0043". On the right, there is a circular logo for "GST/QAF 7.8.2" with "Effective Date: 25 Jan 2021" below it, which is circled in red. The main title "ANALYTICAL REPORT" is centered. Below the title, the following information is provided: Lab ref: 2021-22XP 255; Submitted by: MAXIMUM ENERGY & MINERALS LTD; Received date: 21/01/2022; Reported date: 24/01/2022; #Samples: 1; Pages: 2; Type of Samples: ROCK; Address: DAR ES SALAAM. There are two empty rectangular boxes labeled "Copy" and "Notes". The "Management Signatory" section has a signature "R. WILLIAM" and a stamp. The "Technical Signatory" section has a signature and the name "ISACK RUKWAKWA KAMANA CAMILIUS". At the bottom, there is a disclaimer: "Results in this analytical report pertain to the samples provided to this laboratory for preparation and/or analysis as requested by the client. Geological Survey of Tanzania Conditions of Service apply. This report may not be reproduced except in full, without written permission of the Laboratory. These results are in conformity with ISO/IEC 17025:2017 requirement". The page number "Page 1 of 3" is at the bottom center.

SADCAS
SADC APPLIED CHEMISTRY LABORATORY

TEST-5 0043

ANALYTICAL REPORT

Lab ref: 2021-22XP 255
Submitted by: MAXIMUM ENERGY & MINERALS LTD
Received date: 21/01/2022
Reported date: 24/01/2022
#Samples: 1
Pages: 2
Type of Samples: ROCK
Address: DAR ES SALAAM.

Copy

Notes

Management Signatory
R. WILLIAM
W. R.

Technical Signatory
ISACK RUKWAKWA
KAMANA CAMILIUS

Results in this analytical report pertain to the samples provided to this laboratory for preparation and/or analysis as requested by the client.
Geological Survey of Tanzania Conditions of Service apply
This report may not be reproduced except in full, without written permission of the Laboratory
These results are in conformity with ISO/IEC 17025:2017 requirement

Page 1 of 3



TEST-5 0043



GST/QAF 7.8.2
Effective Date: 25 Jan 2021

ANALYTICAL REPORT

Lab Ref: 2021-22XP 255
Submitted by: MAXIMUM ENERGY & MINERALS LTD
Received date: 21/01/2022
Reported date: 24/01/2022
Type of Samples: ROCK
Sample condition: ACCEPTABLE
Samples: 1

Sample ID	*Au	SiO ₂	Fe ₂ O ₃	SO ₃	P ₂ O ₅	Al ₂ O ₃	CaO	MgO	TiO ₂	K ₂ O	Cu
S-A	< 0.003	6.43	0.58	1.60	0.90	1.30	1.50	0.18	1.00	0.36	147
Method Code	<i>GA01</i>	<i>XRF01</i>	<i>XRF01</i>	<i>XRF01</i>	<i>XRF01</i>	<i>XRF01</i>	<i>XRF01</i>	<i>XRF01</i>	<i>XRF01</i>	<i>XRF01</i>	<i>XRF01</i>
Units	<i>g/ton</i>	<i>%</i>	<i>%</i>	<i>%</i>	<i>%</i>	<i>%</i>	<i>%</i>	<i>%</i>	<i>%</i>	<i>%</i>	<i>ppm</i>
Detection Limit	<i>0.003</i>	<i>0.01</i>	<i>0.01</i>	<i>0.01</i>	<i>0.01</i>	<i>0.01</i>	<i>0.01</i>	<i>0.01</i>	<i>0.01</i>	<i>0.01</i>	<i>0.1</i>
METHOD	<i>BS ISO 10378-2005</i>	<i>GST</i>	<i>GST</i>	<i>GST</i>	<i>GST</i>	<i>GST</i>	<i>GST</i>	<i>GST</i>	<i>GST</i>	<i>GST</i>	<i>GST</i>
Sample ID	Sr	Cl	Zr	V	Zn	Sc	U	Rb	Th	Pb	As
S-A	547	456	122	160	58	46	21	10	8	9	1
Method Code	<i>XRF01</i>	<i>XRF01</i>	<i>XRF01</i>	<i>XRF01</i>	<i>XRF01</i>	<i>XRF01</i>	<i>XRF01</i>	<i>XRF01</i>	<i>XRF01</i>	<i>XRF01</i>	<i>XRF01</i>
Units	<i>ppm</i>	<i>ppm</i>	<i>ppm</i>	<i>ppm</i>	<i>ppm</i>	<i>ppm</i>	<i>ppm</i>	<i>ppm</i>	<i>ppm</i>	<i>ppm</i>	<i>ppm</i>
Detection Limit	<i>0.1</i>	<i>0.1</i>	<i>0.1</i>	<i>0.1</i>	<i>0.1</i>	<i>0.1</i>	<i>0.1</i>	<i>0.1</i>	<i>0.1</i>	<i>0.1</i>	<i>0.1</i>
METHOD	<i>GST</i>	<i>GST</i>	<i>GST</i>	<i>GST</i>	<i>GST</i>	<i>GST</i>	<i>GST</i>	<i>GST</i>	<i>GST</i>	<i>GST</i>	<i>GST</i>

- not analysed | - element not determined | I.S. insufficient sample | L.N.R. listed not received | * Accredited

Management Signatory

MRA

Technical Signatory

[Signature]





SADCAS
SOUTHERN AFRICAN DEVELOPMENT COMMUNITY

TEST-5 0043



GST/QAF 7.8.2
Effective Date: 25 Jan 2021

ANALYTICAL REPORT

Lab Ref: 2021-22XP 255
 Submitted by: MAXIMUM ENERGY & MINERALS LTD
 Received date: 21/01/2022
 Reported date: 24/01/2022
 Type of Samples: ROCK
 Sample condition: ACCEPTABLE
 # Samples: 1

Sample ID	FIXED CARBON (By Calculation)	ASH (DB)	VOLATILE MATTER (DB)	MOISTURE CONTENT (ADB)	GROSS CALORIFIC VALUE	S
S-A	51.31	17.73	30.96	1.90	6553	0.64
<i>Units</i>	%	%	%	%	Kcal/kg	%
<i>METHOD</i>	ASTM D3172	ASTM D3174	ASTM D3175	ASTM D3302	GST	GST

not analysed | - element not determined | I.S. insufficient sample | L.N.R. listed not received | * Accredited



Management Signatory

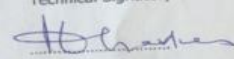

Technical Signatory



Page 3 of 3



TEST-5 0043

ANALYTICAL REPORT

Lab ref: 2021-22XP254
Submitted by: MAXIMUM ENERGY & MINERALS LTD
Received date: 21/01/2022
Reported date: 24/01/2022
#Samples: 1
Pages: 2
Type of Samples: ROCK
Address: DAR ES SALAAM.

Copy

Notes

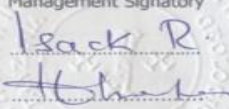
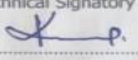
Management Signatory

Technical Signatory

ISACK RUKWAKWA
KAMANA CAMILIUS ✓

Results in this analytical report pertain to the samples provided to this laboratory for preparation and/or analysis as requested by the client. Geological Survey of Tanzania Conditions of Service apply. This report may not be reproduced except in full, without written permission of the Laboratory. These results are in conformity with ISO/IEC 17025:2017 requirement.

Geological Survey of Tanzania
Kikuyu Avenue 01, Dodoma, P. O. Box 903, Dodoma, Tanzania.
t +255 (0)26 232 3020 f +255 (0) 26 232 3020 www.gst.go.tz
Ministry of Minerals

1 of 2



TEST-5 0043



GST/QAF 7.8.2
Effective Date: 25 Jan 2021

ANALYTICAL REPORT

Lab Ref: 2021-22XP254
Submitted by: MAXIMUM ENERGY & MINERALS LTD
Received date: 21/01/2022
Reported date: 24/01/2022
Type of Samples: ROCK
Sample condition: ACCEPTABLE
Samples: 1

Sample ID	*Au	SiO ₂	CaO	Al ₂ O ₃	Fe ₂ O ₃	MgO	SO ₃	TiO ₂	P ₂ O ₃	K ₂ O	Cu
S-K	<0.003	3.29	1.57	0.63	0.71	0.19	1.30	0.64	0.41	0.23	150
Method Code	GA01	XRF01	XRF01	XRF01	XRF01	XRF01	XRF01	XRF01	XRF01	XRF01	XRF01
Units	g/ton	%	%	%	%	%	%	%	%	%	ppm
Detection Limit	0.003	0.01	0.01	0.01	0.01	0.01	0.01	0.01	0.01	0.01	0.1
METHOD	BS ISO 10378-2005	GST	GST	GST	GST	GST	GST	GST	GST	GST	GST

Sample ID	Mo	Zr	Sr	U	Nb	Pb	Zn	Cr	V	Sc	Cl
S-K	7	102	808	32	17	11	35	61	144	150	109
Method Code	XRF01	XRF01	XRF01	XRF01	XRF01	XRF01	XRF01	XRF01	XRF01	XRF01	XRF01
Units	ppm	ppm	ppm	ppm	ppm	ppm	ppm	ppm	ppm	ppm	ppm
Detection Limit	0.1	0.1	0.1	0.1	0.1	0.1	0.1	0.1	0.1	0.1	0.1
METHOD	GST	GST	GST	GST	GST	GST	GST	GST	GST	GST	GST

Sample ID	Fixed Carbon (By calculation)	ASH (DB)	VOLATILE MATTER (DB)	MOISTURE CONTENT (ADB)	GROSS CALORIFIC VALUE	S
S-K	52.56	16.62	30.822	1.61	6662	0.52
Units	%	%	%	%	Kcal/kg	%
Method	ASTM D3172	ASTM D3174	ASTM D3175	ASTM D3302	GST	GST

- not analysed | - element not determined | I.S. insufficient sample | L.N.R. listed not received | * Accredited

Management Signatory

Technical Signatory

**THE UNITED REPUBLIC OF TANZANIA
MINISTRY OF MINERALS
MINING COMMISSION**

PROSPECTING LICENCE NO. PL 11666/2021

GRANTED PURSUANT TO SECTION 32 OF THE MINING ACT, CAP. 123

WHEREAS **M/S Maximum Energy and Minerals Limited** of **P.O. Box 70405, Dar es Salaam - Tanzania** has fulfilled the conditions for grant of Prospecting Licence pursuant to Section 31 of **The Mining Act, Cap. 123**;

I, Eng. Yahya I. Samamba, **ACTING EXECUTIVE SECRETARY**, subject to the provisions of **The Mining Act, Cap. 123** and of the regulations made thereunder or which may come into force during the continuance of this Licence, or any renewal thereof and pursuant to the powers conferred upon me under Section 32 of **The Mining Act, Cap. 123** hereby grant to **M/S Maximum Energy and Minerals Limited** (hereinafter called the Licensee) a **Prospecting Licence - Industrial Minerals**, to prospect for **Coal** at **Masimavarafu** in **Ludewa** District, over an area described in Annex A (hereinafter called the Licence Area), conferring on the Licensee the right to carry on such prospecting operations, abide to Annex B, Annex C and Annex D and execute such other works as are necessary for that purpose.

This Licence, unless sooner cancelled, suspended or surrendered pursuant to the provisions of **The Mining Act, Cap. 123** shall be valid for a period of **forty eight (48)** months, effective from the date of grant.

Granted this ²⁸..... day of ^{July}.....2021

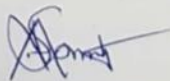

Eng. Yahya I. Samamba
ACTING EXECUTIVE SECRETARY

INITIAL PERIOD

From Date	To Date	Prep. Fee and Rent	ERV Number	Date	Signature of ES
03/07/2021	Preparation fee	USD 300.00	921184055776176		
28/07/2021	27/07/2022	USD 1,905.00	921184055774388	03/07/2021	<i>[Signature]</i>

For: EXECUTIVE SECRETARY
MINING COMMISSION

FIRST RENEWAL

I HEREBY CONSENT TO THE FIRST RENEWAL OF PROSPECTING LICENCE NO. of M/Sof P. O. Box for Licence Area described in Annex 'A' and conditions prescribed in Annex 'B','C' and Annex 'D' for a period of.....months effective from theday of.....year.....

EXECUTIVE SECRETARY

From Date	To Date	Annual Rent	ERV Number	Date	Signature of ES

SECOND RENEWAL

I HEREBY CONSENT TO THE SECOND RENEWAL OF PROSPECTING LICENCE NO. of M/Sof P.O. Box for Licence Area described in Annex 'A' and conditions prescribed in Annex 'B','C' Annex 'D' for a period of.....months effective from theday of.....year.....

EXECUTIVE SECRETARY

From Date	To Date	Annual Rent	ERV Number	Date	Signature of ES

ANNEX A

DESCRIPTION OF THE LICENCE AREA

Subject to Section 95 of the Mining Act, Cap. 123 the Licence is at **Masimavarafu** area in **Ludewa** District, QDS **285/4** defined by lines of latitude and longitude having the following corner coordinates (Arc 1960):

Corner	Latitude	Longitude
1	- 10 deg. 19 min. 15.00 sec.	34 deg. 56 min. 30.00 sec.
2	- 10 deg. 21 min. 20.00 sec.	34 deg. 56 min. 30.00 sec.
3	- 10 deg. 21 min. 20.00 sec.	34 deg. 55 min. 0.00 sec.
4	- 10 deg. 21 min. 28.00 sec.	34 deg. 55 min. 0.00 sec.
5	- 10 deg. 21 min. 28.00 sec.	34 deg. 53 min. 7.00 sec.
6	- 10 deg. 20 min. 0.00 sec.	34 deg. 53 min. 7.00 sec.
7	- 10 deg. 20 min. 0.00 sec.	34 deg. 55 min. 0.00 sec.
8	- 10 deg. 19 min. 15.00 sec.	34 deg. 55 min. 0.00 sec.
1	- 10 deg. 20 min. 47.00 sec.	34 deg. 53 min. 40.00 sec.
2	- 10 deg. 20 min. 56.00 sec.	34 deg. 53 min. 41.00 sec.
3	- 10 deg. 20 min. 52.00 sec.	34 deg. 53 min. 54.00 sec.
4	- 10 deg. 20 min. 46.00 sec.	34 deg. 54 min. 7.00 sec.
5	- 10 deg. 20 min. 33.00 sec.	34 deg. 54 min. 33.00 sec.
6	- 10 deg. 20 min. 27.00 sec.	34 deg. 54 min. 29.00 sec.
7	- 10 deg. 20 min. 21.00 sec.	34 deg. 54 min. 23.00 sec.
8	- 10 deg. 20 min. 27.00 sec.	34 deg. 54 min. 12.00 sec.
9	- 10 deg. 20 min. 32.00 sec.	34 deg. 54 min. 1.00 sec.
10	- 10 deg. 20 min. 36.00 sec.	34 deg. 53 min. 50.00 sec.
11	- 10 deg. 20 min. 40.00 sec.	34 deg. 53 min. 38.00 sec.

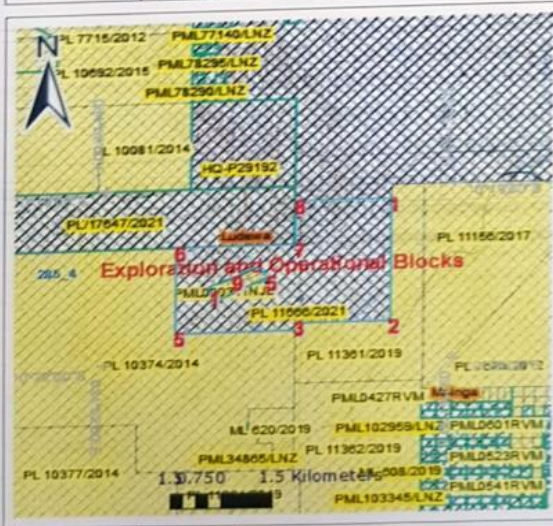

Legend	
Licensed boundary	
Licence Code	PL 11666/2021
District	Ludewa
Direction	

An area of approximately **19.05** Square Kilometres.

ANNEX B

LOCAL CONTENT PLAN

1. The Licensee and their contractor, subcontractor, corporation or other allied entity carrying out mineral prospecting operations shall ensure that local content component is engaged in.
2. Subject to Clause 1 and to the requirement of any law relating to immigration, the Licensee, contractor and its sub-contractor(s) may bring into Tanzania such expatriate personnel as in the Licensee's judgement, required to carry out mineral prospecting operations efficiently and successfully and the Government shall expeditiously provide the necessary work permits and other approvals required for the employment of such expatriate.
3. A non-indigenous Tanzanian company which intends to provide goods or services to a licensee, contractor, subcontractor, corporation or other allied entity within Tanzania carrying out mining activities shall incorporate a joint venture company with an indigenous Tanzanian company and afford that the indigenous Tanzanian company has an equity participation of at least twenty (20%) per centum.
4. The Licensee, contractor, subcontractor, corporation or other allied entity shall procure goods and services (legal, insurance and financial) available in the United Republic of Tanzania in accordance with the approved procurement plan.
5. The Licensee shall on annual basis prepare a credible social responsibility plan jointly agreed by the relevant Local Government Authority or Local Government Authorities in consultation with the Minister responsible for Local Government Authorities and the Minister responsible for Finance.



ANNEX C

PROSPECTING PROGRAMME AND FINANCIAL EXPENDITURE ESTIMATE.

Subject to Section 30 of *The Mining Act, Cap. 123* and Regulation 9 of the Mining (Mineral Rights) Regulations, 2018, the Licensee shall expend on prospecting operations in respect of the licence granted as per submitted prospecting programme and financial expenditure estimates approved by the Mining Commission.

ANNEX D

INTEGRITY PLEDGE

The Licensee shall comply with the Statement of Integrity Pledge.



Appendix v: Mining License

THE UNITED REPUBLIC OF TANZANIA
MINISTRY OF MINERALS
MINING COMMISSION



THE MINING (MINERAL RIGHTS) REGULATIONS, 2018
PRIMARY MINING LICENCE000309NJB
The Mining Act, Cap. 123

The exclusive right, subject to the provisions of *The Mining Act, Cap. 123* and the regulations made thereunder or which may come into force during the continuance of this primary mining licence or any renewal thereof is hereby granted to M/S **Maximum Energy and Minerals Limited of P.O.BOX 70405, Dar es Salaam-Tanzania** (hereinafter called the Licensee), to prospect and mine for **Coal**, at **Masimabhalafu**, in **Ludewa** District, QDS **285/4** over an area described overleaf (Annex A).

This Licence, unless sooner cancelled, suspended or surrendered pursuant to the provisions of *The Mining Act, Cap. 123* shall be valid for a period of **seven (7)** years, effective from the date of grant.

Granted this 12th day of MARCH, 2021

A handwritten signature in blue ink, appearing to read 'Henry J. Mdit'.

.....
Eng: Henry J. Mdit
For: **EXECUTIVE SECRETARY**

PML000309NJB

ANNEX A

DESCRIPTION OF THE PRIMARY MINING LICENCE AREA

The Primary Mining Licence is at **Masimabhalafu** area in **Ludewa** District, QDS **285/4** defined by the following corner co-ordinates (Arc 1960):

Corner	Latitude	Longitude
1	- 10 deg. 20 min. 40.00 sec.	34 deg. 53 min. 38.00 sec.
2	- 10 deg. 20 min. 36.00 sec.	34 deg. 53 min. 50.00 sec.
3	- 10 deg. 20 min. 45.00 sec.	34 deg. 53 min. 52.00 sec.
4	- 10 deg. 20 min. 47.00 sec.	34 deg. 53 min. 40.00 sec.

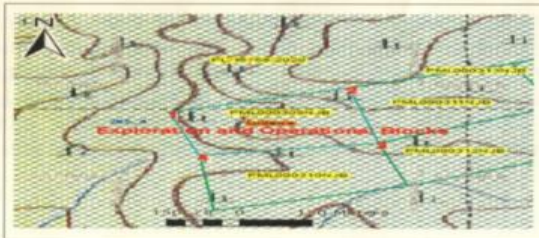

Legend	
Licensed area	
License Number	PML000309NJB
District	Ludewa
Direction	

An area of approximately **9.54** Hectares.

ANNUAL RENT PAYMENTS

Year	ERV	Amount (TShs.)	Date	Signature & Stamp
1.	9210600 25933666	429,300	12/03/2021	
2.
3.
4.
5.
6.
7.

Appendix vi: Ultimate Analysis



Customer Details:
 Maximum Energy and Minerals Limited
 TMS Dear es Siam
 11th Floor P55F Complex
 San Myayma Road

Attention: Oscar Crappo

TEST REPORT

2022

SCS Middlburg Laboratory
 5 West Street
 Industrial Area, Middlburg
 1050

The 013 236 1025

Sampling Information	
Date Sampled:	Unknown
Sampling Method:	Unknown
Sampled by:	Unknown

ITEMS TESTED: COAL SAMPLES

Date Analyzed	Laboratory No.	Job No.	Receiving Weight	Stockpile Name	SUMMARY OF ANALYSIS																					
					As Received Basis				Dry Basis				As Received Basis				As Received Basis									
					ISO 1171	ISO 1198	ISO 92	ASTM D203	ISO 59	ISO 500	ISO 500	ISO 500	ISO 500	ISO 500	ISO 500	ISO 500	ISO 500	ISO 500	ISO 500	ISO 500						
01.03.2022	419503	2022-20	9.98	Maximum	1.78	16.9	26.88	6420	33.0	0.84	17.2	27.37	33.5	0.86	3.9	16.5	28.3	622	32.2	0.8	6039	1460	1500	1500	80	4.2

Tests marked with an * in this report are not included in the SANAS Schedule of Accreditation for this Laboratory.

Approved by: 
 Technical Signatory
 Johannes Phela



Sampling Statement:
 Manual sampling from a static stockpile performed by SGS, as per ISO 1833 Annex B.1. Due to access limitations at the sampling location, increments were collected from freshly exposed static surface of a stockpile, with fixed increment mass. The samples collected have an indicative value and can therefore not be deemed representative of the total Lot. Increments were collected from the safest accessible point in accordance with the Stockpile Operator's rules and regulations.

Sampling Disclaimer:
 The findings of the stored Goods inspection contained herein (the "Findings") relate to and cover examination of part or parts of the Goods safely accessible for inspection in accordance with the client's instructions. The Findings only relate to the time and place of inspection and do not constitute nor are intended to constitute evidence of the existence of part or all of the Goods prior to and after the time of inspection. SGS does not control the storage place of the Goods nor has any responsibility for the storage, custody and safety of the Goods. SGS does not guarantee nor make any representation about (i) the accuracy and authenticity of the documents presented by the operator of the storage place (if any); (ii) ownership of and title to the Goods; (iii) quantity and quality of the Goods. SGS accepts no liability for the consequences of any action taken or not taken on the basis of this certificate/report.

WARNING: The sample(s) to which the findings recorded herein (the "Findings") relate was/were drawn and/or provided by the client or by a third party acting as the Client's direction. The Findings constitute no warranty of the sample's representativity of all goods and strictly relate to the sample(s). The Company accepts no liability with regard to the origin or source from which the sample(s) is/ are said to be extracted. Any unauthorized alteration, forgery or falsification of the content or appearance of this document is unlawful and offenders may be prosecuted to the fullest extent of the law. SGS Middlburg was not responsible for sampling and sample(s) received does not meet minimum mass required to conduct tests as per ISO 1833: Manual Sampling, thus results on this test report relate to the sample(s) received and tested.

This document is issued by the Company under its General Conditions of Service accessible at: <http://www.sgs.com/terms-and-conditions>
 SCS Minerals Services Middlburg Laboratory is accredited by SANAS and conforms to the requirements of ISO/IEC 17025 for specific test or calibrations as indicated on the scope of accreditation to be found at: <http://sanas.co.za>

-End of Report-

GCTL PROJECT Feasibility Report

Appendix vii: Major equipment list

a) Pre-treatment

Equipment	Rating	Quantity
Screw conveyors		2
Crusher/Grinder (Fine)	<1.5mm PSD	2
Slurry blending tank (w/agitator)		2
Slurry storage tank		1

b) Gasification

Equipment	Rating	Quantity
Slurry feed entrained flow gasifier	3000 t/day	2x2
O ₂ compressor (centrifugal)	40 bar p discharge	2
Cold box for ASU	5000 t/day O ₂	2

c) Syngas cleaning

Equipment	Type	Quantity
Selexol H ₂ S absorber	Packed bed	2
CO ₂ absorber	Packed bed	2
Acid gas stripper	Packed bed	2
Stripper reboiler	Shell & tube	2
Lean-rich exchanger	Shell & tube	2
Sulphur plant	Claus process	1
Flash vessels	0.5-20 barg	2
CO ₂ compression	150 barg discharge	1

d) Fischer-Tropsch process

Equipment	Type/Rating	Quantity
Sulphur polisher	ZnO packed bed	2
FT synthesis reactors	5,000 bbl/day slurry reactors	4
CO ₂ removal plant	Amine (2000 t/d CO ₂)	8
CO ₂ compression	150 barg discharge	1
HC recovery	Fractionation	4
H ₂ recovery	PSA	1
Naphtha Hydrotreating	Catalytic bed	1
Distillate Hydrotreating	Catalytic bed	1
Wax Hydrotreating	Catalytic bed	1

e) Auxiliary processes

Equipment
Waste heat boiler
Steam turbine generator
Gas turbine generator
Slag handling system
Auxiliary boiler (coal-fired)
Water treatment plant
Cooling tower

Appendix viii: Commercial CCS facilities and projects worldwide

TITLE	COUNTRY	FACILITY STATUS	OPERATION DATE	FACILITY INDUSTRY	CAPTURE CAPACITY Mtpa CO ₂		FACILITY STORAGE CODE
					MIN	MAX	
Terrell Natural Gas Processing Plant (formerly Val Verde Natural Gas Plants)	United States	Operational	1972	Natural Gas Processing	0.4	0.5	Enhanced Oil Recovery
Enid Fertilizer	United States	Operational	1982	Fertiliser Production	0.1	0.2	Enhanced Oil Recovery
Shute Creek Gas Processing Plant	United States	Operational	1986	Natural Gas Processing	7	7	Enhanced Oil Recovery
MOL Szank field CO₂ EOR	Hungary	Operational	1992	Natural Gas Processing	0.059	0.157	Enhanced Oil Recovery
Sleipner CO₂ Storage	Norway	Operational	1996	Natural Gas Processing	1	1	Dedicated Geological Storage
Great Plains Synfuels Plant and Weyburn-Midale	United States	Operational	2000	Synthetic Natural Gas	1	3	Enhanced Oil Recovery
Core Energy CO₂-EOR	United States	Operational	2003	Natural Gas Processing	0.35	0.35	Enhanced Oil Recovery
Sinopec Zhongyuan Carbon Capture Utilization and Storage	China	Operational	2006	Chemical Production	0.12	0.12	Enhanced Oil Recovery
Snohvit CO₂ Storage	Norway	Operational	2008	Natural Gas Processing	0.7	0.7	Dedicated Geological Storage
Arkalon CO₂ Compression Facility	United States	Operational	2009	Ethanol Production	0.23	0.29	Enhanced Oil Recovery
Century Plant	United States	Operational	2010	Natural Gas Processing	5	5	Enhanced Oil Recovery
Petrobras Santos Basin Pre-Salt Oil Field CCS	Brazil	Operational	2011	Natural Gas Processing	4.6	4.6	Enhanced Oil Recovery
Bonanza BioEnergy CCUS EOR	United States	Operational	2012	Ethanol Production	0.1	0.1	Enhanced Oil Recovery
Coffeyville Gasification Plant	United States	Operational	2013	Fertiliser Production	0.9	0.9	Enhanced Oil Recovery
Air Products Steam Methane Reformer	United States	Operational	2013	Hydrogen Production	1	1	Enhanced Oil Recovery
Lost Cabin Gas Plant	United States	Operation Suspended	2013	Natural Gas Processing	0.7	0.7	Enhanced Oil Recovery
PCS Nitrogen	United States	Operational	2013	Fertiliser Production	0.2	0.3	Enhanced Oil Recovery
Boundary Dam 3 Carbon Capture and Storage Facility	Canada	Operational	2014	Power Generation	0.8	1	Various Options Considered
Quest	Canada	Operational	2015	Hydrogen Production	1.2	1.2	Dedicated Geological Storage
Uthmaniyah CO₂-EOR Demonstration	Saudi Arabia	Operational	2015	Natural Gas Processing	0.8	0.8	Enhanced Oil Recovery
Karamay Dunhua Oil Technology CCUS EOR Project	China	Operational	2015	Methanol Production	0.1	0.1	Enhanced Oil Recovery
Abu Dhabi CCS (Phase 1 being Emirates Steel Industries)	United Arab Emirates	Operational	2016	Iron And Steel Production	0.8	0.8	Enhanced Oil Recovery
Illinois Industrial Carbon Capture and Storage	United States	Operational	2017	Ethanol Production	0.55	1	Dedicated Geological Storage
Petra Nova Carbon Capture	United States	Operation Suspended	2017	Power Generation	1.4	1.4	Enhanced Oil Recovery
CNPC Jilin Oil Field CO₂ EOR	China	Operational	2018	Natural Gas Processing	0.35	0.6	Enhanced Oil Recovery
Gorgon Carbon Dioxide Injection	Australia	Operational	2019	Natural Gas Processing	3.4	4	Dedicated Geological Storage
Qatar LNG CCS	Qatar	Operational	2019	Natural Gas Processing	2.2	2.2	Dedicated Geological Storage

TITLE	COUNTRY	FACILITY STATUS	OPERATION DATE	FACILITY INDUSTRY	CAPTURE CAPACITY Mtpa CO ₂		FACILITY STORAGE CODE
					MIN	MAX	
Alberta Carbon Trunk Line (ACTL) with North West Redwater Partnership's Sturgeon Refinery CO ₂ Stream	Canada	Operational	2020	Hydrogen Production	1.3	1.6	Enhanced Oil Recovery
Alberta Carbon Trunk Line (ACTL) with Nutrien CO ₂ Stream	Canada	Operational	2020	Fertiliser Production	0.2	0.3	Enhanced Oil Recovery
Guodian Taizhou Power Station Carbon Capture	China	In Construction	Early 2020s	Power Generation	0.3	0.3	Enhanced Oil Recovery
Sinopec Qilu Petrochemical CCS	China	In Construction	2021	Chemical Production	0.71	1	Enhanced Oil Recovery
Norcem Brevik - Cement Plant	Norway	In Construction	2024	Cement Production	0.4	0.4	Dedicated Geological Storage
The ZEROS Project	United States	In Construction	2023	Power Generation	1.5	1.5	Enhanced Oil Recovery
Project Interseqt - Hereford Ethanol Plant	United States	Advanced Development	2022	Ethanol Production	0.3	0.35	Dedicated Geological Storage
Project Interseqt - Plainview Ethanol Plant	United States	Advanced Development	2022	Ethanol Production	0.33	0.35	Dedicated Geological Storage
Wabash CO ₂ Sequestration	United States	Advanced Development	2022	Fertiliser Production	1.5	1.75	Dedicated Geological Storage
San Juan Generating Station Carbon Capture	United States	Advanced Development	2023	Power Generation	5.8	6	Under Evaluation
Santos Cooper Basin CCS Project	Australia	Advanced Development	2023	Natural Gas Processing	1.7	1.7	Dedicated Geological Storage
Bridgeport Energy Moonie CCUS project	Australia	Advanced Development	2023	Various	0.12	0.2	Enhanced Oil Recovery
Air Liquide Refinery Rotterdam CCS	Netherlands	Advanced Development	2024	Hydrogen Production	0.8	0.8	Dedicated Geological Storage
ExxonMobil Benelux Refinery CCS	Netherlands	Advanced Development	2024	Hydrogen Production	-	-	Dedicated Geological Storage
Shell Refinery Rotterdam CCS	Netherlands	Advanced Development	2024	Hydrogen Production	0.9	1.4	Dedicated Geological Storage
Air Products Refinery Rotterdam CCS	Netherlands	Advanced Development	2024	Hydrogen Production	-	-	Dedicated Geological Storage
Atkinson Biorefinery Carbon Capture and Storage	United States	Advanced Development	2024	Ethanol Production	0.14	0.16	Dedicated Geological Storage
Fairmont Biorefinery Carbon Capture and Storage	United States	Advanced Development	2024	Ethanol Production	0.3	0.33	Dedicated Geological Storage
Otter Tail Biorefinery Carbon Capture and Storage	United States	Advanced Development	2024	Ethanol Production	0.14	0.16	Dedicated Geological Storage
Shenandoah Biorefinery Carbon Capture and Storage	United States	Advanced Development	2024	Ethanol Production	0.21	0.23	Dedicated Geological Storage
Superior Biorefinery Carbon Capture and Storage	United States	Advanced Development	2024	Ethanol Production	0.15	0.17	Dedicated Geological Storage
Wood River Biorefinery Carbon Capture and Storage	United States	Advanced Development	2024	Ethanol Production	0.31	0.34	Dedicated Geological Storage
York Biorefinery Carbon Capture and Storage	United States	Advanced Development	2024	Ethanol Production	0.13	0.14	Dedicated Geological Storage
Central City Biorefinery Carbon Capture and Storage	United States	Advanced Development	2024	Ethanol Production	0.3	0.33	Dedicated Geological Storage
Aberdeen Biorefinery Carbon Capture and Storage	United States	Advanced Development	2024	Ethanol Production	0.12	0.14	Dedicated Geological Storage
Casselton Biorefinery Carbon Capture and Storage	United States	Advanced Development	2024	Ethanol Production	0.43	0.5	Dedicated Geological Storage
Galva Biorefinery Carbon Capture and Storage	United States	Advanced Development	2024	Ethanol Production	0.09	0.11	Dedicated Geological Storage

GCTL PROJECT Feasibility Report

TITLE	COUNTRY	FACILITY STATUS	OPERATION DATE	FACILITY INDUSTRY	CAPTURE CAPACITY Mtpa CO ₂		FACILITY STORAGE CODE
					MIN	MAX	
Goldfield Biorefinery Carbon Capture and Storage	United States	Advanced Development	2024	Ethanol Production	0.18	0.22	Dedicated Geological Storage
Grand Junction Biorefinery Carbon Capture and Storage	United States	Advanced Development	2024	Ethanol Production	0.29	0.34	Dedicated Geological Storage
Granite Falls Biorefinery Carbon Capture and Storage	United States	Advanced Development	2024	Ethanol Production	0.15	0.18	Dedicated Geological Storage
Heron Lake Biorefinery Carbon Capture and Storage	United States	Advanced Development	2024	Ethanol Production	0.16	0.19	Dedicated Geological Storage
Huron Biorefinery Carbon Capture and Storage	United States	Advanced Development	2024	Ethanol Production	0.08	0.09	Dedicated Geological Storage
Lamberton Biorefinery Carbon Capture and Storage	United States	Advanced Development	2024	Ethanol Production	0.13	0.16	Dedicated Geological Storage
Lawler Biorefinery Carbon Capture and Storage	United States	Advanced Development	2024	Ethanol Production	0.49	0.57	Dedicated Geological Storage
Marcus Biorefinery Carbon Capture and Storage	United States	Advanced Development	2024	Ethanol Production	0.39	0.46	Dedicated Geological Storage
Mason City Biorefinery Carbon Capture and Storage	United States	Advanced Development	2024	Ethanol Production	0.29	0.34	Dedicated Geological Storage
Merrill Biorefinery Carbon Capture and Storage	United States	Advanced Development	2024	Ethanol Production	0.13	0.16	Dedicated Geological Storage
Mina Biorefinery Carbon Capture and Storage	United States	Advanced Development	2024	Ethanol Production	0.34	0.4	Dedicated Geological Storage
Nevada Biorefinery Carbon Capture and Storage	United States	Advanced Development	2024	Ethanol Production	0.22	0.26	Dedicated Geological Storage
Norfolk Biorefinery Carbon Capture and Storage	United States	Advanced Development	2024	Ethanol Production	0.13	0.15	Dedicated Geological Storage
Onida Biorefinery Carbon Capture and Storage	United States	Advanced Development	2024	Ethanol Production	0.19	0.23	Dedicated Geological Storage
Plainview Biorefinery Carbon Capture and Storage	United States	Advanced Development	2024	Ethanol Production	0.27	0.32	Dedicated Geological Storage
Redfield Biorefinery Carbon Capture and Storage	United States	Advanced Development	2024	Ethanol Production	0.15	0.17	Dedicated Geological Storage
Sioux Center Biorefinery Carbon Capture and Storage	United States	Advanced Development	2024	Ethanol Production	0.16	0.19	Dedicated Geological Storage
Steamboat Rock Biorefinery Carbon Capture and Storage	United States	Advanced Development	2024	Ethanol Production	0.19	0.23	Dedicated Geological Storage
Watertown Biorefinery Carbon Capture and Storage	United States	Advanced Development	2024	Ethanol Production	0.32	0.37	Dedicated Geological Storage
Wentworth Biorefinery Carbon Capture and Storage	United States	Advanced Development	2024	Ethanol Production	0.22	0.26	Dedicated Geological Storage
Fortum Oslo Varme - Klemetsrud Waste to Energy Plant	Norway	Advanced Development	2024	Waste Incineration	0.4	0.4	Dedicated Geological Storage
Coyote Clean Power Project	United States	Advanced Development	2025	Power Generation	0.86	0.86	Under Evaluation
Stockholm Exergi BECCS	Sweden	Advanced Development	2025	Bioenergy	0.8	0.8	Dedicated Geological Storage
Copenhill (Amager Bakke) Waste to Energy CCS	Denmark	Advanced Development	2025	Waste Incineration	0.5	0.5	Dedicated Geological Storage
Lake Charles Methanol	United States	Advanced Development	2025	Chemical Production	4	4	Dedicated Geological Storage
Abu Dhabi CCS Phase 2: Natural gas processing plant	United Arab Emirates	Advanced Development	2025	Natural Gas Processing	1.9	2.3	Dedicated Geological Storage
Ons Earth Energy Facility Carbon Capture	United States	Advanced Development	2025	Ethanol production	0.5	0.5	Dedicated Geological Storage
Project Tundra	United States	Advanced Development	2025 - 2026	Power Generation	3.1	3.6	Various Options Considered
Humber Zero - VPI Immingham Power Plant CCS	United Kingdom	Advanced Development	2027	Power Generation	-	-	Dedicated Geological Storage

GCTL PROJECT Feasibility Report

TITLE	COUNTRY	FACILITY STATUS	OPERATION DATE	FACILITY INDUSTRY	CAPTURE CAPACITY Mtpa CO ₂		FACILITY STORAGE CODE
					MIN	MAX	
Humber Zero - Phillips 66 Humber Refinery CCS	United Kingdom	Advanced Development	2028	Hydrogen Production	–	–	Dedicated Geological Storage
Antwerp@C - BASF Antwerp CCS	Belgium	Advanced Development	2030	Chemical Production	–	–	Dedicated Geological Storage
OXY and Carbon Engineering Direct Air Capture and EOR Facility	United States	Advanced Development	Mid 2020s	Direct Air Capture	0.5	1	Dedicated Geological Storage
Mustang Station of Golden Spread Electric Cooperative Carbon Capture	United States	Advanced Development	Mid 2020s	Power Generation	1	1.5	Under Evaluation
Plant Daniel Carbon Capture	United States	Advanced Development	Mid 2020s	Power Generation	1.6	1.8	Dedicated Geological Storage
Gerald Gentleman Station Carbon Capture	United States	Advanced Development	Mid 2020s	Power Generation	4.3	4.3	Under Evaluation
Prairie State Generating Station Carbon Capture	United States	Advanced Development	Mid 2020s	Power Generation	5	6	Dedicated Geological Storage
Cal Capture	United States	Advanced Development	Middle 2020s	Power Generation	1.4	1.4	Enhanced Oil Recovery
Midwest AgEnergy Blue Flint ethanol CCS	United States	Early Development	2022	Ethanol Production	0.18	0.18	Dedicated Geological Storage
Velocys' Bayou Fuels Negative Emission Project	United States	Early Development	2025	Chemical Production	0.4	0.5	Dedicated Geological Storage
Project Pouakai Hydrogen Production with CCS	New Zealand	Early Development	2024	Various	1	1	Under Evaluation
Red Trail Energy BECCS Project	United States	Early Development	2025	Ethanol Production	0.18	0.18	Dedicated Geological Storage
Clean Energy Systems Carbon Negative Energy Plant - Central Valley	United States	Early Development	2025	Power Generation and Hydrogen Production	0.32	0.32	Dedicated Geological Storage
Preem Refinery CCS	Sweden	Early Development	2025	Hydrogen Production	0.5	0.5	Dedicated Geological Storage
Acorn Hydrogen	United Kingdom	Early Development	2025	Hydrogen Production	–	–	Dedicated Geological Storage
HyNet North West - Hanson Cement CCS	United Kingdom	Early Development	2026	Cement Production	0.8	0.8	Dedicated Geological Storage
Repsol Sakakemang Carbon Capture and Injection	Indonesia	Early Development	2026	Natural Gas Processing	1.5	2	Dedicated Geological Storage
Ravenna Hub - ENI Power CCS	Italy	Early Development	2026	Power Generation	–	–	Dedicated Geological Storage
Ravenna Hub - ENI Hydrogen CCS	Italy	Early Development	2026	Hydrogen Production	–	–	Dedicated Geological Storage
G2 Net-Zero LNG	United States	Early Development	2027	Natural Gas Processing	4	4	Under Evaluation
Net Zero Teesside - BP H2Teesside	United Kingdom	Early Development	2027	Hydrogen Production	1	2	Dedicated Geological Storage
Net Zero Teesside - Suez Waste to Energy CCS	United Kingdom	Early Development	2027	Waste Incineration	–	–	Dedicated Geological Storage
ZERO Carbon Humber - Keady 3 CCS Power Station	United Kingdom	Early Development	2027	Power Generation	1.5	2.6	Dedicated Geological Storage
Antwerp@C - Ineos Antwerp CCS	Belgium	Early Development	2030	Chemical Production	–	–	Dedicated Geological Storage
Antwerp@C - Exxonmobil Antwerp Refinery CCS	Belgium	Early Development	2030	Chemical Production	–	–	Dedicated Geological Storage
Antwerp@C - Borealis Antwerp CCS	Belgium	Early Development	2030	Chemical Production	–	–	Dedicated Geological Storage
Korea-CCS 1 & 2	South Korea	Early Development	2020s	Power Generation	1	1	Dedicated Geological Storage
Sinopec Shengli Power Plant CCS	China	Early Development	2020s	Power Generation	1	1	Enhanced Oil Recovery

GCTL PROJECT Feasibility Report

TITLE	COUNTRY	FACILITY STATUS	OPERATION DATE	FACILITY INDUSTRY	CAPTURE CAPACITY Mtpa CO ₂		FACILITY STORAGE CODE
					MIN	MAX	
Dave Johnston Plant Carbon Capture	United States	Early Development	2020s	Power Generation	2	6	Enhanced Oil Recovery
NextDecade Rio Grande LNG CCS	United States	Early Development	2020s	Natural Gas Processing	5	5	Under Evaluation
Caledonia Clean Energy	United Kingdom	Early Development	2024	Power Generation	3	3	Dedicated Geological Storage
Hydrogen 2 Magnum (H2M)	Netherlands	Early Development	2024	Power Generation	2	2	Dedicated Geological Storage
Dry Fork Integrated Commercial Carbon Capture and Storage (CCS)	United States	Early Development	2025	Power Generation	3	3	Dedicated Geological Storage
Net Zero Teesside - CCGT Facility	United Kingdom	Early Development	2025	Power Generation	1.7	6	Dedicated Geological Storage
The Illinois Clean Fuels Project	United States	Early Development	2026	Chemical Production	4.1	8.1	Dedicated Geological Storage
Northern Gas Network H21 North of England	United Kingdom	Early Development	2026	Hydrogen Production	1.5	1.5	Dedicated Geological Storage
Hydrogen to Humber Saltend	United Kingdom	Early Development	2026-2027	Hydrogen Production	1	1.2	Dedicated Geological Storage
Drax BECCS Project	United Kingdom	Early Development	2027	Power Generation	1	4.3	Dedicated Geological Storage
Ervia Cork CCS	Ireland	Early Development	2028	Power Generation and Refining	2.5	2.5	Dedicated Geological Storage
Nautical Energy Blue Methanol	Canada	Early Development	Late 2020s	Methanol Production	1	1	Enhanced Oil Recovery
Net Zero Teesside - NET Power Plant	United Kingdom	Early Development	Late 2020s	Power Generation	–	–	Under Evaluation
PAU Central Sulawesi Clean Fuel Ammonia Production with CCUS	Indonesia	Early Development	Late 2020s	Fertiliser Production	0.1	2	Under Evaluation
Saskatchewan NET Power Plant	Canada	Early Development	Late 2020s	Power Generation	0.95	0.95	Under Evaluation
Tata Steel project EVEREST	Netherlands	Early Development	Late 2020s	Iron and Steel Production	–	–	Under Evaluation
Acorn CCS	United Kingdom	Early Development	Mid 2020s	Natural Gas Processing and Oil Refining	0.34	0.34	Dedicated Geological Storage
HyNet North West	United Kingdom	Early Development	Mid 2020s	Hydrogen Production	1.5	1.5	Dedicated Geological Storage
LafargeHolcim Cement Carbon capture	United States	Early Development	Mid 2020s	Cement Production	1	2	Under Evaluation
Barents Blue Clean Ammonia with CCS	Norway	Early Development	2025	Fertiliser Production	1.2	2	Dedicated Geological Storage
Petronas Kacawari Gas Field Development Project	Malaysia	Early Development		Natural Gas Processing	–	–	Under Evaluation
Polaris CCS Project	Canada	Early Development	Middle 2020s	Hydrogen Production	0.75	0.75	Dedicated Geological Storage
Caroline Carbon Capture Power Complex	Canada	Early Development	Middle 2020s	Power Generation	1	3	Dedicated Geological Storage
Acorn Direct Air Capture Facility	United Kingdom	Early Development	2026	Direct Air Capture	0.5	1	Dedicated Geological Storage

Notes 1

Notes 2

Notes 3



Maximum Energy and Minerals Limited Company is planning to build a 20,000 barrels per day green coal to liquids (GCTL) plant in Ludewa district, Njombe region in Tanzania. Maximum Energy and Mineral Limited Company owns a reserve base of 323.18 million tonnes of bituminous coal, and therefore committed to bring this project to life. The planned plant is expected to reduce Tanzania's dependency on imported liquid fuels (diesel and petrol/gasoline) by approximately 34%. Using advanced technology maximum energy is planning a net zero CO₂ emission plant by 2030, a commitment to green rehabilitation of mined areas and hence set a unique world class example of responsibility towards humanity and the environment.