

# OILCOM (T) LIMITED

## PROPOSED BUSINESS PLAN

### FOR

## THE ESTABLISHMENT OF PRODUCTION OF LIQIFIED PETROLEUM GAS, BULK STORAGE, CYLINDER AND TRUCK FILLING INDUSTRY IN KURASINI INDUSTRIAL AREA, ILALA, DAR ES SALAAM REGION, TANZANIA.



**Prepared by:**  
OILCOM (T) LIMITED,  
PLOT NUMBER 312.4  
KURASINI INDUSTRIAL AREA,  
ILALA DISTRICT,  
P O BOX 71731,  
DAR ES SALAAM,  
TANZANIA

MAY, 2022

## Table of content

List of Abbreviations .....	4
<b>EXECUTIVE SUMMARY</b> .....	5
<b>1.0. BUSINESS OVERVIEW AND BACK GROUND INFORMATION</b> .....	7
1.1. Overview – Oil and Gas sector in Tanzania. ....	7
1.2. The opportunity of harnessing gas resources for investing in growth .....	7
1.3. Domestic versus Export Market .....	9
1.4. The company overview .....	9
1.5. Project concept in Kurasini industrial area .....	11
1.5.1. Mounded bullets and accessories.....	11
1.5.2. Bullet corrosion protection.....	12
1.5.3. Safety fittings, pumps and LPG piping.....	13
1.5.4. Firefighting system .....	14
1.5.5. electrical system and cubbing .....	15
1.5.6. other utilities and accessories .....	16
1.5.7. Jetty Piping .....	16
1.5.8. Filling shed equipment's .....	16
<b>2.0. PROJECT OVERVIEW</b> .....	19
2.1. The Industry.....	19
2.2. Business Plan Objectives .....	19
2.3. Project Technical aspect – gas refinery production process: .....	20
2.3.1. Explanatory note of natural gas .....	20
<b>2.3.2. Natural gas refinery production process</b> .....	20
2.4. Project establishment Overview .....	22
<b>2.4.1. Project description</b> .....	22
2.5. Technical Characteristic of the project. ....	23
2.5.1. Project Location and site analysis.....	23
2.5.2. Buildings and related fixed cost .....	24
2.5.3. Machinery and Equipment.....	24
2.5.4.. Motor Vehicles .....	25
2.5.5. Furniture & Fittings and computers.....	25
2.5.6. Pre-Operational Expenses.....	25
2.5.7. Initial Working Capital .....	25
2.5.8. Project Financing.....	25
2.5.9. Project Implementation.....	25
2.5.10. Auxiliary Materials/ services .....	26
2.5.12. Warehousing and distribution.....	27
2.5.13. Waste management for industry .....	27
<b>3.0. MANPOWER AND SALARY BUDGET</b> .....	28
3.1. Employment .....	28
3.2. Recruitment .....	28
3.3. Training and the use of Consultants .....	28
3.4. Organization and Management.....	28
<b>4.0. PROJECT FINANCING AND CAPITAL INVESTMENT SUMMARY</b> .....	31
4.1. Project Cost & Financing Pattern .....	31
4.2. Project Capital Investment Summary .....	31
<b>5.0. RISK ANALYSIS</b> .....	33
5.1. Risk Analysis .....	33
5.2. Macroeconomic risk analysis .....	33
5.3. Finance risk analysis.....	33
5.4. Other potential external risk .....	33
5.4. Mitigating potential risk .....	34
<b>6.0. ECONOMIC AND SOCIAL ASPECTS</b> .....	35
<b>6.1. Impact Investment Index Framework</b> .....	35
<b>7.0. FINANCIAL MODELLING AND ANALYSIS</b> .....	37

7.1. Project investment inputs and revenue projects.....	37
7.2. Production, Revenue and project viability.....	37
7.3. Objective and Scope of Financial Model.....	38
7.3.1. Objective.....	38
7.3.2. Scope.....	38
7.3.3. Project financial plan.....	38
<b>ANNEX I – INCOME STATEMENT.....</b>	<b>39</b>
<b>ANNEX II – CASH FLOW.....</b>	<b>40</b>
<b>ANNEX III – BALANCE SHEET.....</b>	<b>41</b>
<b>ANNEX IV - IRR.....</b>	<b>42</b>
<b>ANNEX V PAY BACK PERIOD.....</b>	<b>42</b>
<b>8.0. CONCLUDING REMARKS AND WAY FORWARD.....</b>	<b>43</b>
8.1. Evidence of project viability based on financial model and policy.....	43
Framework support.....	43
8.2. Policy Framework Support.....	43
8.3. Conclusive Remarks and Way Forward.....	44

## **List of Abbreviations**

4WD – Four Wheel Driver  
CAPEX – Capital Expenditure  
CIF- Central in Flight  
EU – European Union  
GDP – Growth Domestic Products  
IRR – Internal rate of return  
Kg – kilo gram  
LTD - Limited  
MIS - Management Information System  
MT – Metric Ton  
MW – Mega Watts  
NBS – National Bureau of standard  
NEMC – National Environment Management Council  
OPEX – Operating Expenditure  
SIDO- Small Development Organization  
SWOC – Strength Weakness Opportunity Challenge  
TANESCO – Tanzania Electric Supply Company  
TIC- Tanzania Investment Centre  
TZS – Tanzania Shilling  
UK – United Kingdom  
US\$ - United State Dollar  
USA - United state of America  
VAT – Value Added tax  
VETA - Vocation Education Training Authority

## **EXECUTIVE SUMMARY**

OILCOM Tanzania Limited imports, distributes, and markets premium-quality petroleum products across East and Central Africa. OILCOM was incorporated on the 20th of July, 1990, as a company limited by shares under the Companies Ordinance. In the past years OILCOM has expanded rapidly in the sub regional petroleum business. The headquarters of OILCOM is in Dar es Salaam, the main port and commercial capital of Tanzania, and from there the wings of investment spread out to the neighboring countries of Malawi, Rwanda, Zambia, Kenya, and the Democratic Republic of Congo. The main goal of OILCOM is focused on commitment, efficiency and customer satisfaction.

OILCOM is one of the Major Company in On-Shore Bunkering to various Military Vessels, Offshore Drilling Rigs, Commercial Shipping Lines, Tug Boats, Marine Vessels, Speed Boats, Chase Boats, Seismic Survey Vessels, etc. OILCOM has recently set up its own LPG Storage at Dar es Salaam with a capacity of 500 Metric Tons and has become one of the major players in the Tanzanian market in a very short time.

The company aimed to expand her production by producing Gas by purchasing 3750MTX4 NOS Mounded Bullets complete set machineries, Heavy LPG trucks and other utilities vehicles. Machines and equipment's will be imported from different countries in the world such as India/EUA, China, France and USA.

The project will be established by complying to NFPA 56 and SANS 10067-3, 2015 standard. The plant will be located to plot No. 312.4 at Kurasini Industrial area, in Dar Es Salaam Region. Whereas the yard is already secured with necessary amenities and gas production facilities.

The company will Refinery gas sweetening is the process used to purify a gas stream for further use in a process. Storage tanks for gas production, the anticipated capacity of 4 storage tanks with capacity of 3,750MT per tank. The construction of Tanks will build with high quality moulded bullet with total capacity of 15,000MT which will make the largest plant in Tanzania and the second largest in Eastern Africa after AGOL in Mombasa, Kenya. The proposed integrated project is estimated to cost a total of US\$ 50,450,493.70 this including, own equity of 100% US\$ 50,450,493.70 as proceeds from capital contribution of the project. The Current asset of US\$ 5,563,975 during the first year of operation and it increase as the project will be in full operation (see income statement), fixed assets 50,102,668US\$ and total liquidity of 116,956,165US\$. The project will be implemented within 5 years.

The basis for pricing has been from observations and data collected from various parts of Tanzania, market value for exploration is estimated to 3400TZS per Kilogram which is equivalent to 1.4USD per Kilogram. In MT equivalent to 1400US\$ as selling price.

The company anticipate to sale in a wholes price at 1304US\$ per MT. according to the projections the monthly anticipated revenue is estimated to 9,456,521.74US\$ per 7,250MT. for annual sales the total sales will be 113,478,261US\$ Including packaging facilities;

The development of a large and complex project such as OILCOM (T) LIMITED is necessarily accompanied by multiple risks during all the phases of the project development, construction, operation and maintenance. The right approach to manage the project in a manner which is fairly and adequately address the multiple risks in a comprehensive as well as systematic manner is very important.

Based on the Impact Investment Index analysis, the company can develop projections that the project can deliver both value for money in the context of broad socioeconomic impact

and return on investment while complying with governance requirements. In this regard therefore, OILCOM (T) LIMITED will promote the industrialization process in the country, create employment, attract new technologies, expand foreign exchange earnings and ultimately contribute substantially to the country's economic growth.

On the basis of all the analysis done on this Business Plan on all aspects of assessment on both SWOC Analysis, market analysis, risk analysis and the financial analysis, the proposed investment options in the drilling and exploration as prescribed on this business plan have shown that the project is commercially viable. Nonetheless, OILCOM (T) LIMITED through professional consultative manner, will continue to find ways of implementing cost effective options given time and financial resources that will be made available. Financial analysis results show that when the construction of project facility is financed using a combination of equity debt ratio (100:0), it gives an IRR of about 9.81%. The computed IRR is well above Dollar market of the annual loan interest rate of (8.00%) which is technically interpreted that the project is financially viable. The payback period for the project is estimated at 4 to 5 years, which is within the range for this type of investment. Sensitivity analysis results also favor the project.

The whole process of production lines is looking at providing direct employment to at least 278 permanent jobs on full implementation and operation of the project.

## **1.0. BUSINESS OVERVIEW AND BACK GROUND INFORMATION.**

### **1.1. Overview – Oil and Gas sector in Tanzania.**

Tanzania has been exploring for oil and gas for the past 60 years since 1952. The first natural gas discovery was made in 1974 on the Songo Songo Island (Lindi Region) followed by a second discovery at the Mnazi Bay (Mtwara Region) in 1982. The Songo Songo natural gas was commercialized in 2004 and that of the Mnazi Bay in 2006.

The commercialization of the two discoveries propelled further exploration both on- and off-shore. In 1999 petroleum exploration in the deep sea commenced with the shooting of speculative seismic survey along the entire East African coastal area after which the deep-sea Tanzania was divided into blocks.

In 2005 the first exploration license in the deep-sea was awarded. In 2010, these exploration endeavors culminated in large quantities of natural gas discoveries. Exploration continues and more gas discoveries are anticipated. Natural gas has become an increasingly important energy source around the world, and its importance is expected to increase in the coming decades as demand continues to rise and new sources of supply are exploited.<sup>1</sup>

With rising global interest in natural gas has come an enormous expansion in exploration and discovery including, in the last decade, in the Indian Ocean off the East African coast, yielding significant finds. While exploration activity around these finds has been dominated by international oil and gas firms – both ‘majors’ and independents – the development of the fields will draw the Government of Tanzania directly into the sector and will also start to generate potentially large flows of revenue to government.

The natural gas sector therefore represents a hugely beneficial opportunity for Tanzania. If used efficiently, a natural resource windfall can contribute to poverty reduction and help place the country on a successful and inclusive economic growth path. But as is widely appreciated, the transition to substantially increased natural resource dependence is far from straightforward and places considerable demands on government and key stakeholders to develop a coherent medium- term economic and political strategy for the management of the resource windfall. Close attention is required across a range of areas, including: fiscal and monetary policy formulation; industrial and trade policy; skills, training and employment; and the development of robust and transparent institutional foundations for effective inclusive growth. This note provides some brief background to the natural gas sector in Tanzania and then outlines the main opportunities and challenges facing the country.

### **1.2. The opportunity of harnessing gas resources for investing in growth**

The opportunity of harnessing gas resources for investing in growth The newly-discovered natural gas reserves offers gains in four areas: (i) taking advantage of rising global demand for natural gas; (ii) improving the domestic fuel mix to more efficiently meet domestic energy demands; (iii) exploiting new sources of comparative advantage in production for the domestic and regional markets and, as a consequence, supporting sectorial diversification and employment generation; and (iv) using public tax revenues in the development of physical and human infrastructure capital.

---

<sup>1</sup> [https://www.tanzania.go.tz/egov\\_uploads/documents/Natural\\_Gas\\_Policy\\_-\\_Approved\\_sw.pdf](https://www.tanzania.go.tz/egov_uploads/documents/Natural_Gas_Policy_-_Approved_sw.pdf)

Exporting to the global market International trade in gas has been bolstered by the development of liquefied natural gas (LNG) transportation and the construction of an intercontinental network of pipelines. Given their strategic location, West African countries, like Nigeria and Angola, have the possibility to develop exports towards Europe and North America. East African producers, including Tanzania and Mozambique may export to the neighboring countries, to the Middle East and the fastest growing region of the world, East and South Asia. By 2040, Asia is expected to become the leading consumer of natural gas in the world, accounting for almost 40% of global demand

Meeting local energy demands Thanks to its versatility, gas can be used extensively in the industrial sector and by enabling a reliable and affordable access to energy, gas can help reduce energy costs and contribute to a sectorial diversification of the economy.

### **Power generation:**

In recent years the Tanzanian economy has been constrained by a combination of high cost and intermittent supply of reliable power. Tanzania's national electric supply company TANESCO has been forced to substitute towards high-cost oil-fired generation while firms and households have had to rely on high-cost stand-by generators.

Between 2009 and 2011 the sharp decline in electricity supply has been a critical factor in the slow-down of growth. Even for gas-importing countries, producing electricity from gas-fired power plants is an attractive option: in fact, the transformation of natural gas into power is the largest component of usage of natural gas worldwide, amounting to 40% of total gas usage. Economies of scale in general raise the possibility that exporting power rather than gas itself to neighboring countries may be a high-return activity.

### **Sectorial diversification:**

Gas can also be used in the production processes of a wide range of industries as a chemical feedstock and as a fuel source for industrial heating. Its low carbon intensity and the need for limited processing before end-use make it a choice fuel and feed stock for the production of fertilizers, petrochemicals and for high energy-consuming industries. Production of ammonia and fertilizer: Ammonia produced from natural gas is the chief ingredient of the nitrogenous fertilizer, representing 60-70% of the cost of nitrogenous fertilizer production, which translates into a reduction of fertilizer prices by up to US\$155-US\$175 per ton. Conversion to Liquid fuels: natural gas can be converted to a variety of liquid fuels, such as methanol, diesel, ethanol and gasoline. Though ethanol and diesel can be produced from natural gas, the chemical conversion process involved is more capital intensive and less efficient than the one for methanol. Also, methanol can be easily exported, as the global demand for it is huge. Alternatively, methanol can be used to produce formaldehyde, which can be further processed to produce plastics, paints and explosives.

### **Industrial Heating:**

Process heating is a crucial manufacturing process in the production of metals, coal products, rubber, plastic, concrete, cement, glass and ceramic. Natural gas provides an

efficient alternative for industrial process heating with a much reduced environmental impact. CNG: Natural gas in its compressed form, CNG, is an efficient source of cooking fuel for households, restaurants and for centralized cooling facilities of large-scale retail customers like hotels and office buildings. But, the cost of constructing CNG pipelines to households is huge. CNG can also be used to fuel light duty cars, substituting gasoline in ordinary gasoline engines with minor transformation. Although the investments required to establish adequate infrastructures across cities is colossal, it could help reduce importations of oil and environmental impacts of the transport sector.

### **1.3. Domestic versus Export Market**

**Domestic versus Export Market** The allocation of a finite supply of gas production between domestic and export markets is a delicate balancing act. The value of increased supply to the domestic market – for energy and to support downstream development, particularly given projections on population growth, industrial development and urbanization – needs to be traded off against the requirement of a guaranteed minimum throughput of natural gas to the LNG/export sector in order to justify the extremely high capital costs of constructing LNG trains. Striking this balance between competing legitimate concerns will require a transparent and coherent policy framework for the sector combined with careful and flexible management capable of responding to changing market conditions and developmental concerns.

Currently in Tanzania there is a dichotomy between the large multinational mining companies and the artisanal Gas production. OILCOM (T) LIMITED will seek to exploit this dichotomy in gas opportunities; it will operate in a way that will add value to artisanal gas and oil while not troubling the larger oil companies. The company provides the following services: distributes, and markets premium-quality petroleum products across East and Central Africa<sup>2</sup>

### **1.4. The company overview**

OILCOM Tanzania Limited imports, distributes, and markets premium-quality petroleum products across East and Central Africa. OILCOM was incorporated on the 26th of July, 1990, as a company limited by shares under the Companies Ordinance. In the past years OILCOM has expanded rapidly in the sub regional petroleum business. The headquarters of OILCOM is in Dar es Salaam, the main port and commercial capital of Tanzania, and from there the wings of investment spread out to the neighboring countries of Malawi, Rwanda, Zambia, Kenya, and the Democratic Republic of Congo. The main goal of OILCOM is focused on commitment, efficiency and customer satisfaction.

OILCOM has its own Depots at Strategic locations with following Storage Capacities. In Tanzania, 76,000 Cu3 in Dar es Salaam 4,800 Cu3 in Mtwara 6,000 Cu3 in Isaka (Near Kahama) 2,200 Cu3 in Kigoma In Democratic Republic of Congo, 8,000 Cu3 in Lumumbashi In Zambia, 5,000 Cu3 in Lusaka In Malawi, 2,500 Cu3 in In Rwanda, 18,000 Cu3 in Kigali OILCOM has Aviation Fueling Facilities at Dar es Salaam International Airport, Mwanza Airport & Kigoma Airport in Tanzania.

OILCOM is one of the Major Company in On-Shore Bunkering to various Military Vessels, Offshore Drilling Rigs, Commercial Shipping Lines, Tug Boats, Marine Vessels,

---

<sup>2</sup> <https://www.theigc.org/wp-content/uploads/2014/08/Background-note.pdf>

Speed Boats, Chase Boats, Seismic Survey Vessels, etc. OILCOM has recently set up its own LPG Storage at Dar es Salaam with a capacity of 500 Metric Tons and has become one of the major players in the Tanzanian market in a very short time. OILCOM is supported by its own sister company Al-Hushoom Investments which is the back bone of OILCOM in transportation of Petroleum Products through East & Central Africa with fleet of more than 400 Trucks. OILCOM Petro Card helps its customers to fuel their vehicles from the nearest OILCOM Petrol Station within Dar es Salaam and presently at few strategic locations within up-country areas 24x7.<sup>3</sup>

---

<sup>3</sup> [https://rocketreach.co/oilcom-tanzania-limited-profile\\_b5df746bf42e487a](https://rocketreach.co/oilcom-tanzania-limited-profile_b5df746bf42e487a)

### 1.5. Project concept in Kurasini industrial area

The proposed aimed to expand her oil production by purchasing major equipment's for installation of the factory 3750MTX4 NOS Mounded Bullets, these includes the following, Mounded bullets and accessories, Bullet corrussion Safety fittings, pumps and LPG piping; Firefighting system; Electrical system and cubbing; Other utilities and accessories; Jetty Piping and Filling shed equipment's. All these machines and equipment's will be imported from different countries in the world such as India/EUA, China, France and USA.

#### 1.5.1. Mounded bullets and accessories.

<i>Sr. No.</i>	<i>Item Description</i>	<i>Country of Origin</i>	<i>Qty</i>	<i>Unit</i>
	<b><u>PART A- MOUNDED BULLETS</u></b>			
A.1	SA 537 Class 2 of Steel for LPG Mounded Tanks to store 3750 MT of LPG Storage Tank with Design pressure of 17.5 Bar. 13.3 Meter Internal Diameter as per ASME Sec VIII Div 2 Design	India / China	5200	MT
A.2	Supply of Flanges , Fittings, Nozzle Pipes + Other Hardware Material for LPG Mounded Tanks	India/ China	80	MT
A.3	Welding Electrodes (Various Types) for the Mounded Storage Tanks	India/ Saudi Arabia/Indonesia	240	MT
A.4	Gridning and Cutting Wheels	India/ Korea/Taiwan	2	MT
A.5	Welding Machines (400 amp, 600 amp and 1000 amp) along with Panel and Cabling 200 m each for the Tank Fabrication	India/ Korea/Taiwan	50	Nos
A.6	Crane for the Tank Erection, 400 MT	India/China	1	Nos
A.7	Crane for the Tank Erection, 80 MT	India/China	2	Nos
A.8	Crane for the Tank Erection, 20 MT	India/China	2	Nos
A.9	Scaffolding Pipes along with required number of Clamps	India/China	250	MT
A.10	Other Fabrication machinery along with lifting and shifting equipments, tools and tackles	India/China	1	Lot
A.11	Rolling Machines for the Plate Rolling Machine, 75mm Thick x 3 m wide	India	1	Nos

**1.5.2. Bullet corrosion protection**

<b><u>PART B- BULLET CORROSION PROTECTION AS PER NACE STD</u></b>				
B.1	Epoxy Paint along with Primer and Thinner Material for the Mounded Type Storage Tank	India/UAE	43000	Lit
B.2	Copper Slag (15MT	India	262.5	MT
B.3	Airless Epoxy Pianting Machines	India/US	3	Nos
B.4	Impressed Current Cathodic Protectiuon system with a Design Life of 50 Years and Working Life of 30 Years. With Anodeflex 5000 Anodes. Duly Certified by NACE IV Level Technician. With Monolithic Joints for Flange Isolation for all the Bullets	India	5	Sets

### 1.5.3. Safety fittings, pumps and LPG piping

<b>PART C- SAFETY FITTINGS, PUMPS AND LPG PIPING</b>				
C.1	Safety fittings for Each Tank shall Consist of One Number Servo Level Guage + One Number of Radar Level Guage + Temp and Pressure Transmitter + Temp and Pressure Guage + Safety Valves.	Swiss/ Germany/India	4	Sets
C.2	Complete Inventory Management Software TFMS system of with Provision to Control Incoming and Outgoing Material status	India	4	Sets
C.3	Remote Opted Valves Storage Tank Liquid Outlet Nozzle (1 Nos Each Bullet) at the Bottom, 12" NB Storage Tank Liquid Inlet Nozzle (2 Nos Each Bullet) at the Top, 12" NB Storage Tank Vapour Inlet and Outlet (1 Nos Each Bullet) at the Top, 4"NB Storage Tank Liquid Return Line (1 Nos Each Bullet) at the Top, 4"NB	India	4	Sets
C.4	LPG Cylinder Filling Pumps (Multistage)	Germany/France	3	Nos
C.5	Road Tanker Loading Pumps (Multistage)	Germany/France	5	Nos
C.6	Tanker Unloading/Evacuation Compressor (1 Working + 1 Stand By) Tanker Loading 3 Inch NB / Unloading Arm 2 inch NB for <b>Eight</b> Bays. Each Unloading Aram will consisi of QCDC Coupling + BreakAway Coupling + Swivel Type Loading Arm of 3" Liquid and 2" NB Vapour line + Sight Flow Glass for Liquid Line + NRV for Liquid Line + Necessary Ball Valves and Other safety Fittings	India	2	Nos
C.7	Mass Flow Meter :- Tanker Liquid Loading Line 1 Nos- 3" NB Tanker Vapour Loading/Unloading line 1 Nos – 2" NB	India, Sweden	8	Sets
C.8	Batch Controller System for Tanker Loading system with Auto Cut off system and complete MIS	Italy/ India	1	Sets
C.9	Fire Safe Ball Valves of Class 300 (Various Sizes from 14 Inch to 1/2 Inch)	Italy/ India	250	Nos
C.10	Forged Flanges and Fittings	India/China	65	MT
C.11	SS304 U-Clamps + SS304 Gaskets + Earthing Copper Jumpe	Italy/ India	1	Sets
C.12	Interconnecting LPG Product Piping of ASA 106 Gr B Sch 40/80	India/China	250	MT

#### 1.5.4. Firefighting system

<b>PART D- FIRE FIGHTING SYSTEM</b>				
D.1	-Fire Water Engine Complete Set with Engine + Pump + Battery + Heat Exchanger + Fuel tank + Stack	India	3	Nos
D.2	Fire fighting Jockey Pump of 40 cum per Hr 80 Meter Head	India	2	Nos
D.3	SA 36 Gr B / Q275R Steel for Fire Water Tank along with structural Material	India/China	200	MT
D.4	-Fire Extinguisher 10 Kg Capacity (DCP + ABC)	India	40	Nos
D.5	-Fire Hydrant with hose and Hose Box, 63mm Nozzle with 1800LPM Water Flow Rates	India/UAE	7	Nos
D.6	-Fire Monitors 63mm, UL Approved	India/UAE	7	Nos
D.7	-Galvalised ERW (API 5L) Pipe Thick. Hydrant of Piping (Various sizes from 1 1/2 inch to 24 Inch)	India/China	150	MT
D.8	-Medium Velocity Sprinkler Nozzle (Model K22 with 120 Deg), UL approved System for Sphere + LPG Pump room + LPG Tanker Loading Shed + LPG Cylinder Filling Shed.	India/UAE	1000	Nos
D.9	-Medium Velocity Sprinkler Nozzle System for LPG Jetty and piping	India/UAE	100	Nos
D.10	-Deluge Valve system for Bullets Sprinkler along with Low and High Pressure Switch system. Dry Type Gong , 80 NB	India/UAE	2	Nos
D.11	-Deluge Valve system for Filling Shed along with Low and High Pressure Switch system. Dry Type Gong , 80 NB	India/UAE	4	Nos
D.12	-Deluge Valve for Pump Shed along with Low and High Pressure Switch system. Dry Type Gong , 80 NB	India/UAE	4	Nos
D.13	-Deluge Valve for Tanker Loading Shed along with Low and High Pressure Switch system. Dry Type Gong , 80 NB	India/UAE	4	Nos
D.14	-Deluge Valve for LPG Jetty along with Low and High Pressure Switch system. Dry Type Gong	India/UAE	1	Nos

### 1.5.5. electrical system and cubbing

<i><b>PART E- Electrical System and Cabling</b></i>				
E.1	Electrical Transformer 2000 KVA and Sub-station	India	1	Nos
E.2	Diesel Generator 1000 KVA	India	2	Nos
E.3	Diesel Generator 100KVA	India	2	Nos
E.4	Lighting System-Well Head Lamps, Flameproof Enclosed, 40W LED Light	India	72	Nos
E.5	Lighting System- High Mast	India	6	Nos
E.6	Lightning Arrestor, 60 m radius with Pole	India	6	Nos
E.7	Earthing System- Static Earthing + Electrical Equipment Earthing	India	1	Lot
E.8	Main Incomer Cable	India	2000	Nos
E.9	Cable Trays	India	1	Lot
E.10	Power Factor Control Panel.	India	1	Lot
E.11	PMCC (Process Motor Control Centre)	India	1	Lot
E.12	Process Distribution Board	India	1	Lot
E.13	Light Distribution Board.	India	1	Lot
E.14	UPS Panel 10 KVA. Minimum.( With Battery Bank )	India	1	Lot
E.15	PLC Panel	India	1	Lot
E.16	Operator station As HMI ( Computer with Hard Disc and A4 Printer.)	India	1	Lot
E.17	Flame Proof ON/OFF Switches	India	1	Lot
E.18	Fire Fighting Panel	India	1	Lot
E.19	FLP Junction Box	India	1	Lot
E.20	Leak Detection system - Infra Red Type ( 30 Nos of Sensors), Honeywell USA	India	30	Nos
	Fire Resistant Power Cabels (XLPE INSULATED,EXTRUDED			
E.21	PVC ST2 INNERSHEATHED,SINGLE GI ROUND WIRE ARMOUR,FRLS PVC ST2 OUTERSHEATHED CABLE)	India	1	Lot
E.22	Fire Resistant Instrumentation Cables	India	1	Lot

### 1.5.6. other utilities and accessories

<b><i>PART F - Other Utilities and Accessories</i></b>				
F.1	Air Compressor- Screw Type Air Compressors	Italy/India	3	Nos
F.2	Pipeline Safety Fittings Like Thermal Stress Relief Valves, Pressure Guages, temperature Guages , Needle Valves etc	India	1	Lot
F.3	Epoxy Paint along with Primer and Thinner Material for the Piping	India/UAE	3000	Lit

### 1.5.7. Jetty Piping

<b><u>PART G - Jetty Piping</u></b>				
G.1	-Pipeline from Shore to Bullet for Liquid 12"NB (ASA 106 Sch 80, 3LPE Coated)- 2500 Meters	India/China	2500	Meters
G.2	-Pipeline from Shore to Bullet for Vapour 4"NB (ASA 106 Sch 80, 3LPE Coated) - 2500 Meters	India/China	2500	Meters
G.3	- Marine Grane Ball Valves and Other Instruments for Onshore Jetty Isolatoion	India / Europe	1	Lot
G.4	- Unloading Hose with High Mast Liquid 12 Inch NB x 25 m Long	India	2	Nos
G.5	- Unloading Hose with High Mast Vapour 4 Inch NB x 25 m Long	India	2	Nos

### 1.5.8. Filling shed equipment's

<b><u>PART I - FILLING SHED EQUIPMENTS</u></b>				
I.1	6 Kg Cylinder Filling Line with with 24 Post Carousel Unit (18000 Cyl per Day)	France		
I.2	6 or 15 Kg Cylinder Filling Line with with 12 Post Carousel Unit (4000 Cyl of 15 Kg per Day)	France		
I.3	38 Kg Cylinderx 5 Nos Sationery Filling Scales with (1000 Cyl per Day Min)	France		
I.4	Packing	France		
I.5	Transport	France		
I.6	Installation and Commissioning	France		
<b><u>PART J - STEEL REBARS &amp; PROFILES FOR CIVIL WORKS</u></b>				
J.1	Assorted Rebars Civil Structures	India/China		MT
J.2	Assorted Steel Profiles for Civil Structures	India/China		MT

However the company is already involve in purchasing of said Oil and Gas production equipment's as will result of the significant investment in Tanzanian operations, the company is looking to register at the Tanzania investment Center. For that purpose, this business plan is prepared to outline the required information about the company and the operations being conducted for the Tanzania Investment Centre only. It is to be considered private and confidential.

The company will be established a layout of the project which is prepared to comply to NFPA 56 and SANS 10067-3, 2015 standard. The plant will be located to plot No. 312.4 at Kurasini Industrial area, in Ilala District, Dar Es Salaam Region. Whereas the yard is already secured with necessary amenities and gas production facilities. Other major capital expenditure will involve procurement of workshop tools and equipment, modern processing machines and equipment; purchase of utility motor vehicles, furniture and fittings, and fencing of the project sites:

#### **1.4. The company objectives include the followings;**

- i. To carry on the business of producer, refinery, stores, supplies, and distributors of petroleum and its products and explore for, produce, refine, treat, distil, manufacture, smelt, store, transport, use, experiment with, market, distribute, exchange, purchase, sell and otherwise dispose of any kind of petroleum products, oil, gas and other volatile substance,
- ii. To construct, erect, equip and carry on the business of petrol station with all usual or convenient building, petrol an oil pumps, plant of the said business, to carry on the business of garage proprietor's, service proprietor's, mechanical engineering, manufactures, etc
- iii. To tender for and enter contracts of manufacturing, procurement, and supply of equipment and machinery in the industry.
- iv. To carry on the business of importers and exporters of heavy plant and equipment.

#### **1.5. Project setup at Kurasini industrial area – Dar es salaam, Tanzania.**

The second phase of this project proposal entails setting up yard for gas facilities, so that customers may equipped of all gas laboratories facilities from using modern technology. The project will be created in the said site above. The proposed project will therefore involve the following activities:

- ❖ Additional Acquisition of mentioned machineries and equipment's to ensure maximum production of final mining products
- ❖ Development of processing camps and infrastructure
- ❖ Construction of laboratories building, storage warehouses, workshops and offices
- ❖ Importation and installation of gas processing plants, laboratory for noble metal testing
- ❖ Procurement and installation of environmental protection plant equipment
- ❖ Importation and installation of equipment, machinery and plants for gas processing
- ❖ Procurement of heavy duty trucks fleet for transportation of gas and tailings. Other utility vehicles will also be procured for the project. This will include pickups, 4-WD station wagons to facilitate movement. Armored vehicles will also be procured for transportation.
- ❖ Purchase of furniture, equipment, fittings and administration motor vehicles, fencing of the factory compound and storage yard.

## 2.0. PROJECT OVERVIEW

### 2.1. The Industry

OILCOM (T) LIMITED is a Tanzanian company registered in Tanzania with certificate of incorporation number 18300 of 26th of July, 1990 The Company with Taxpayer Identification Number 100-143-690. OILCOM has expanded rapidly in the sub regional petroleum business. The headquarters of OILCOM is in Dar es Salaam, the main port and commercial capital of Tanzania, and from there the wings of investment spread out to the neighboring countries of Malawi, Rwanda, Zambia, Kenya, and the Democratic Republic of Congo. The main goal of OILCOM is focused on commitment, efficiency and customer satisfaction.

The main office of the company is located at Kurasini, mandela road, plot No. 312/4 Mandela road, Ilala district, Dar Es Salaam City in Tanzania. The anticipated project site will be located at the same plot the permanent address is P O Box 71731 Dar Es Salaam.

The initial Authorized Share Capital of the company is TZS 100,000/= divided into 100 ordinary shares of TZS 1,000/= each and the company have the power to divide the original or any increased capital into several classes, and to attach thereto any preferential, deferred, qualified or other special rights privileges, restrictions or conditions. Unless the conditions of issues shall otherwise expressly declare, every issue of shares, whether preference or otherwise, or any such rights, privileges or conditions shall not be altered or modified except in accordance with the registered Articles or Association. The liability of the members is limited and the following names compromise the company ownership and principal shareholding as illustrated on Table 1 below.

**Table 2.1. Company Ownership and Principal Shareholders**

S/No.	Shareholder's Name	Address	Occupation of Subscriber	Number of Shares
1.	HAROON PIRMOHAMED (TANZANIAN)	P O BOX 71731, DAR ES SALAAM, TANZANIA	Private Company By Share, Domicile In Tanzania- Incorporate Number 18300	1
2.	PIRMOHAMED ABDULRAHIM PILMOHAMED (TANZANIAN )	P O BOX 1406, IRINGA, TANZANIA	Private Company By Share, Domicile In Tanzania- Incorporate Number 18300	1

### 2.2. Business Plan Objectives

The objectives of this study are two-fold. First is to determine the viability of the proposed project and serve as a business plan for the company's development program. Secondly, the business plan will act as a supporting document in the company's application for Tanzania Investment Centre (TIC) Certificate of Incentives so as to access exemptions on duties, VAT deferrals and other benefits and protections as statutorily provided for under Tanzania Investment Act (1997).

The project promoters have commissioned a reputable engineering and project planning consulting firm to advise on detailed technical and economic evaluation of the project and in determining its viability. As the report will be used to raise debt financing for the project, it is tailored to meet standard requirements of financial institutions in the region.

### **2.3. Project Technical aspect – gas refinery production process:**

#### **2.3.1. Explanatory note of natural gas**

*Natural gas is a vital component of the world's supply of energy. It is one of the cleanest, safest, and most useful of all energy sources. Despite its importance, however, there are many misconceptions about natural gas. For instance, the word 'gas' itself has a variety of different uses, and meanings. When we fuel our car, we put 'Gas' in it. However, the gasoline that goes into your vehicle, while a fossil fuel itself, is very different from natural gas. The 'gas' in the common barbecue is actually propane, which, while closely associated and commonly found in natural gas, is not really natural gas itself. While commonly grouped in with other fossil fuels and sources of energy, there are many characteristics of natural gas that make it unique.*

#### **2.3.2. Natural gas refinery production process**

Refinery gas sweetening is the process used to remove the so called 'Acid Gasses' which are hydrogen sulfide and carbon dioxide from the refinery gas streams. These acid gas removal processes used in the refinery are required either to purify a gas stream for further use in a process or for environmental reasons. Clean Air legislation now being practiced through most industrial countries require the removal of these acid gases to very low concentrations in all gaseous effluent to the atmosphere. Hydrogen Sulfide combines with the atmosphere to form very dilute sulfuric acid and carbon dioxide to form carbonic acid both of which are considered injurious to personal health. These compounds also cause excessive corrosion to metals and metallic objects.

The process development and description the use of chemically 'basic' liquids to react with the acidic gases was developed in 1930. The chemical used initially was Tri ethanol amine (TEA). However, as Mono ethanol amine (MEA) became commercially more available it became the preferred liquid reactant due to its high acid gas absorption on a unit basis.

The molecular weight of MEA is 61 while that for TEA is 149. As both react mole for mole with the acid gases 2.44 lbs of TEA must be circulated to achieve the same absorptive capacity as 1 lb of MEA. TEA also suffers degradation at temperatures above its boiling point and as this is its regeneration temperature MEA has replaced TEA in this service. Since 1955 numerous alternative processes to MEA have been developed. These have fewer corrosion problems and are to a large extent more energy efficient. Inhibitor systems have however been developed which have eliminated much of the MEA corrosion problems. Some of these newer processes also are designed to selectively remove the H<sub>2</sub>S leaving the CO<sub>2</sub> to remain in the

gas stream. The process flow and description of the more common processes are essentially the same. This process flow is shown in Figure 2.1

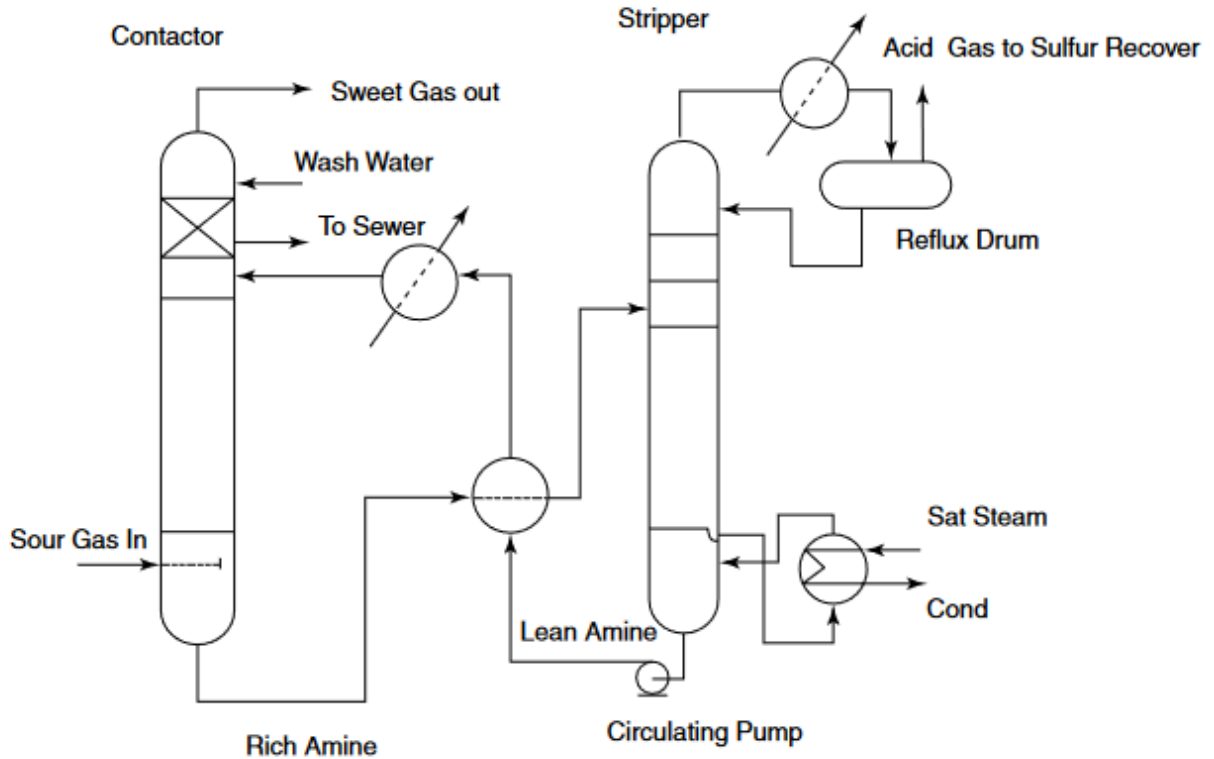

For product gas streams which must meet lower than 1 grain per scf of  $H_2S$ , MEA must be used. This amine, however, is degraded by certain sulfide compounds found in gas from thermal crackers. The most common compound that degrades MEA is carbonyl sulfide (COS). MEA can, however, be regenerated by batch or continuous vaporization and disposal of the sludge formed by the degeneration. Referring to the above flow sheet, sour gas (rich in  $H_2S$ ) enters the bottom of the trayed absorber (or contactor). Lean amine is introduced at the top tray of the absorber

section to move down the column. Contact between the gas and amine liquid on the trays results in the  $H_2S$  in the gas being absorbed into the amine. The sweet gas is water washed to remove any entrained amine before leaving the top of the contactor. Rich amine leaves the bottom of the contactor to enter a surge drum. If the contactor pressure is high enough a flash stream of  $H_2S$  can be routed from the drum to a trayed stripper.

## 2.4. Project establishment Overview

### 2.4.1. Project description

OILCOM (T) LIMITED aimed at expanding her petroleum production process by establish **production of liquefied petroleum gas, bulk storage, cylinder and truck filling industry** at Kurasini industrial area in Dar es Salaam, Tanzania. The company will Refinery gas sweetening is the process used to purify a gas stream for further use in a process. The company will purchase the following set complete set of gas production facilities as prescribed section 1.5 to this report. Storage tanks for gas production, the anticipated capacity of 5 storage tanks with capacity of 3,750MT per tank. The construction of Tanks will build with high quality moulded bullet with total capacity of 15,000MT which will make the largest plant in Tanzania and the second largest in Eastern Africa after AGOL in Mombasa, Kenya. From moulded, the bullets will be of sounded by land and covered by high grade reinforced concrete which enhance storage safety.



*LPG mounded tank*

### 2.4.2. Cylinder bottling capacity

The plant anticipate to install 3 state of automatic filling machines from Eurpo and other maanual filling machines for eavy cylinders. The break down of the proposed bottling capacity is as follows;

Machine No#	Size	Cylinder/Truck Size	Filling Capacity/Month (No. of Cylinders/Trucks)	Filling Capacity/Month (MT)
Filling Carousel 1	24 Post	6Kg	450,000	2,700
Filling Carousel 2	12 Post	6Kg	200,000	1,200
Filling Carousel 3	12 Post	15kg	100,000	1,500
Stand Alones	5 Post	38Kg	15,000	570
Bulk Trucks Loading	8 Bays	20MT	64	1,280
<b>TOTAL MONTHLY CAPACITY (MT)</b>				<b>7,250</b>

*Table 1- Monthly Cylinder Bottling Capacity*

The basis for pricing has been from observations and data collected from various parts of Tanzania, market value for exploration is estimated to 3400TZS per Kilogram which is equivalent to 1.4USD per Kilogram. In MT equivalent to 1400US\$ as selling price. The company anticipate to sale in a wholes price at 1304US\$ per MT. according to the projections the monthly anticipated revenue is estimated to 9,456,521.74US\$ per 7,250MT, annually 87,000MT. For annual sales the total sales will be 113,478,261US\$ including packaging facilities;

<u>Revenue</u>						
	<u>Year 1</u>	<u>Year 2</u>	<u>Year 3</u>	<u>Year 4</u>	<u>Year 5</u>	<u>TOTAL</u>
Yearly sales of Gas	113,478,261	119,152,174	125,109,783	137,620,761	151,382,837	646,743,815
<b>Total Operating Revenue</b>	<b>113,478,261</b>	<b>119,152,174</b>	<b>125,109,783</b>	<b>137,620,761</b>	<b>151,382,837</b>	<b>646,743,815</b>

## 2.5. Technical Characteristic of the project.

### 2.5.1. Project Location and site analysis

Based on physical inspection of the proposed site at Kurasini industrial area, the availability of basic and essential industrial infrastructure such transport, water supply, effluent disposal, electric power supply, telecommunication system and security were all checked out and are ok for factory establishment. The realization of the project development requires successful completion of a number of necessary activities and facilities to enable a successful development of the project. The project location is already installed necessary utilities such as reliable supplies of energy, water, transportation, telecommunications services, waste disposal and other services are in place.

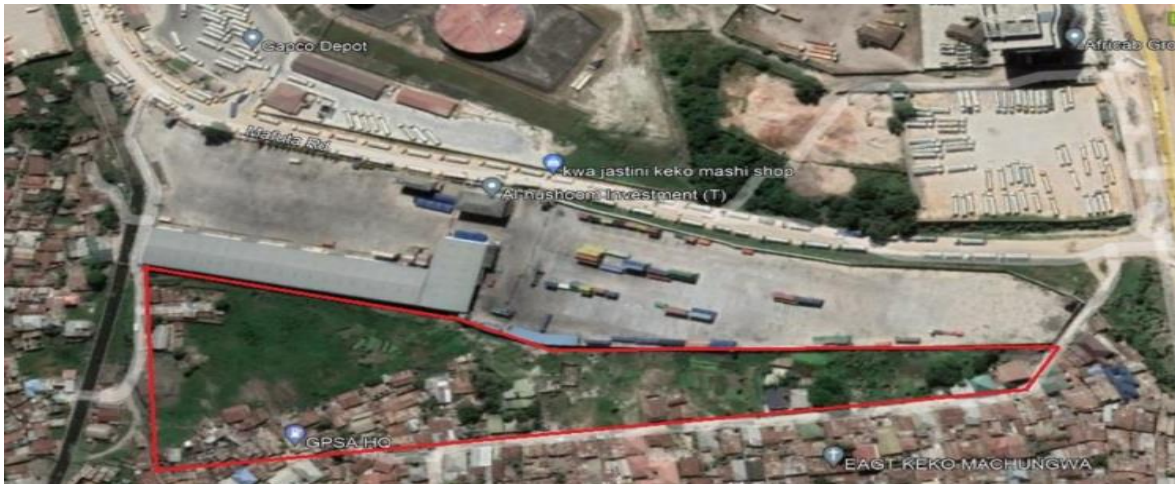

### 2.5.2. Buildings and related fixed cost

The floor plan and elevation of buildings and other related structures will be rehabilitating to OILCOM (T) LIMITED as rented at Kurasini New industrial area by the shareholders. However, the total major rehabilitation of the yard and buildings, Storage of raw materials and finished processing a structure, the estimated cost of buildings 76,696.26US\$, the cost includes Renting, rehabilitation of administration building and offices, Laboratories, storages of chemicals and spare parts, workshop, and camp. The industry also set budget as working capital which involves purchase of raw materials and factory overhead cost of 65,217.39US\$ The minor rehabilitations costs are inclusive of contingency and reflect prevailing cost of building materials and other cost.

### 2.5.3. Machinery and Equipment.

Proper machinery selection is one of the key problems in the development of an industry. The machinery must suit the two-fold requirements of the developing countries, i.e. it should be up-to-date to allow for competitive production. In view of the foregoing, an effort has been made to choose from modern technological alternatives, a level that strikes a balance between fixed costs based on depreciation and variable costs based essentially on wages.

The requirements of various items of equipment have been worked out taking into consideration the production programs, average equipment utilization and normal productivity level of an average worker etc. While working out details of equipment required, it has been assumed that the plant will be working in a double shift of 16 hours a day, 25 days a month or a total of 300 days a year.

The projects machinery and equipment will be sourced from Europe and Asia are estimated to cost 27,786,841US\$, this includes, Mounded bullets and accessories, Bullet corrusion Safety fittings, pumps and LPG piping; Firefighting system; Electrical system and cubbing; Other utilities and accessories; Jetty Piping and Filling shed equipment's. All these machines and equipment's will be imported from different countries in the world such as India/EUA, China, France and USA. All these will be able to produce 15,000MT per single entry, and the plant capacity is to produce 7,250MT per month. Equivalent to 9,456,521.74US\$ per Month, totaling to 113,478,260.87 per year.

The total cost of machineries and equipment's is estimated to 27,786,841US\$US\$, these cost assumptions are C.I.F Dar es Salaam and include installation, commissioning, consultancy, port charges and transport to the project site. Calculated depreciation of machines and other working facilities is estimated to cost 795,129US\$ and increases tremendously.

#### **2.5.4.. Motor Vehicles**

100 heavy LPG Trucks worth 20,000,000US\$, 50 distribution/ supporting trucks worth 2,000,000US\$, 5 Light vehicle plants worth 100,000US\$will purchased for this project totaling to 22,100,000US\$

#### **2.5.5. Furniture & Fittings and computers**

This cost item includes the purchase of various office furniture: tables, chairs cabinets, safes, telecommunication gadgets, firefighting equipment, air conditioners etc. A budget of 32,609.7US\$ will be allocated from general administration budget for furniture fittings and computer accessories. The total budget for furniture and fittings is small due to nature of industry as few or minor requirement of furniture and fittings.

#### **2.5.6. Pre-Operational Expenses**

Under pre-operational expenses are considered costs like company formation, preliminary project studies, business plan preparation costs, licenses, permits and authorization, including processing of TIC Certificate of Incentives, and legal fees, travelling expenses, initial recruitment and training expenses, and interest accrued during project construction period. Budget allocated for this is 21,391.30US\$

#### **2.5.7. Initial Working Capital**

This item will mainly cover initial imports of raw materials estimated to last for the first three months of operations. Otherwise, raw materials will generally be maintained at one month's stock and debtors at one month's sales volume constitute the biggest portion of current assets. Trade credits will be 15 days for the items listed. The initial working capital allocated budget is 130,434.78US\$.

#### **2.5.8. Project Financing**

The project costs, including fixed costs (machinery, equipment, building renovations, motor vehicles, office furniture and equipment and pre-operation expenses will be financed by a combination of bank term loan and shareholders own resources. Working capital requirements will be financed by short term bank financing in form of overdraft facility. The project promoters are planning to finance project cost in the following pattern:

#### **2.5.9. Project Implementation**

Full implementation of the project is planned to take place by end of June 2022. Machineries and motor vehicles will be imported immediately while construction/renovation works are in process.

### **2.5.10. Auxiliary Materials/ services**

Falling under this category is packing bags, paper for bags for bran, lubricants, grease and other miscellaneous items.

**Utilities and service facilities that will need to be provided in this plant are as follows:**

- (i) Workshop
- (ii) Electric power
- (iii) Water supply
- (iv) Miscellaneous facilities {Canteen; First Aid Kit, Storage and transport and Office Facilities}

#### **(i) Workshop**

It is necessary to make provision for a small workshop in the plant premises so that certain maintenance operations could be carried out following sudden breakdowns and major routine matters. The facility will comprise of necessary machines like small centre lathe, drilling machine, welding set, soldering and gas-cutting equipment including complete electrical kit to take care of necessary electrical maintenance as well as to replace worn-out parts and periodic oil and greases needs for the plant. Equipment provision has been restricted to the minimum.

#### **(ii) Electric Power and Generator**

The proposed site will be supplied with industrial production 3-phase standard power supply from Tanzania Electric Supply Company (TANESCO), the electricity is available through the National Grid Line from Kinyerezi, Dar es Salaam the main power station distributor and electric transformer 2000KVA substation nearby the project site. There also a two diesel generator with a capacity 1000KVA each. Lighting system well head Lamps, flamed enclosed with 40W led light will be installed. As part of an alternative power supply, the company will install UPS system in case of abruptly power cut off with a capacity of 10KVA minimum with a battery bank.

#### **(iii) Water Supply**

Apart from the needs of electric power, water is also required for the actual process and other social needs. The proposed site has close to DAWASCO - Dar es Salaam Urban water supply Authority water network, the agency is major supplier of water to urban and peri urban area in the region. The main line from this source will be tapped and let to the land site and water collected in an overhead reservoir provided at the top of the building of the plant. Adequate provision has been made in the project cost for the overhead tank and supply and laying of pipelines etc.

#### **(iv) Miscellaneous Facilities e.g. First Aid Kit, Storage and Transport, Office Facilities etc**

- Provision has been made in the project costs for necessary facilities for external telephones and fire alarm system;

- Sickness and ill-health are recognized to be among the cause of absenteeism and low morale leading to decreased production, increased waste and bad employee-management relations. Therefore, necessary provision has been made for the canteen and first aid facilities in case of accidents, sudden sickness etc.
- Necessary provision for furniture and office equipment has been made in the Capital Cost estimates.
- Provision has also been made for the various types of weighing equipment in various sections for material-handling equipment etc.

#### **2.5.12. Warehousing and distribution**

The Oilcom (T) Limited's warehousing service is ready to meet 24/7/365 in provision of drilling services and necessary material and chemicals imported. The efficiency of on-site combined with focal lift is already accommodated all needs and reduce supply chain costs. The industry uses electronics inventory management system means will ready for the efficiently movements of goods to next level.

The industry will use quick dispatch for fast distribution of final products and packed by manual means or by semi-automatic machines. The industry will take Extra care is therefore taken to make it hygienic so that the products do not get spoiled during storage.

#### **2.5.13. Waste management for industry**

In order to create a sustainable society, it is necessary to develop effective utilization of all sorts of wastes. One of the major wastes from our living is fiber wastes. Fiber wastes are generally divided to nonindustrial (organic chemicals) and industrial wastes (inorganic Chemicals)

In his strategic management for Oilcom (T) Limited's; the industry has to move from an understanding of improvement at all costs to an understanding of continuous and balanced improvement once established. In modern times, environmental protection is being implemented not because it is enforced law, but as an administrative philosophy.

Rapid degradation in environmental conditions has changed at attitude of industrial managers toward ecological environment and had them consider ecology a significant factor while taking decisions related to industrial management. Parameters responsible for environmental pollution include chemicals discharged into air, water and soil as well as energy pollution all these will be taken into consideration of the proposed project.

Noise pollution caused by poorly planned settlement programs is also included in this plan. Furthermore, safety and health of those working in production will be also taken into account by installing modern machines free from noise pollution.

### **3.0. MANPOWER AND SALARY BUDGET**

#### **3.1. Employment**

The whole process of production lines is looking at providing direct employment to at least 278 permanent jobs on full implementation and operation of the project. The industry is divided into 4 Departments; Administration and finance (12), Management (29), Maintenance (25), Operation (189) and store and logistic (23)

#### **3.2. Recruitment**

Recruitment of the operation department personnel's will be carried out by giving first preference to ex-technician from our local technical institutes such as Vocation Education Training Authority "VETA" and employees of OILCOM (T) LIMITED in Tanzania, based on demonstration of skills and aptitude basis and their willingness to work for OILCOM (T) LIMITED. Careful methodology is being worked out by a competent management consultant who will set the job descriptions. To ensure that the right calibre is recruited. Recruitment of expatriate personnel will be carried out in consultation with the relevant authorities in Government and the collaborating agencies.

#### **3.3. Training and the use of Consultants**

The Company plans to initially carry out on the job training for most of the technical staff to be dispatched to the project site by the suppliers of the plant which will be specified under sales agreement. In general the company will ensure that employees acquire new skills and procedures to increase their productivity fourfold. Educational materials will be subsidized or paid for to motivate the workers to develop themselves.

Whereas the company will endeavor to obtain the best talents to fill the permanent posts in the organization, it is intended where necessary, to continue with the policy of hiring out some specialized skills by way of consultants. Alternatively, those skills not required throughout the year will be left to consultants. These include legal counsels, systems and management consultants. To ensure efficient and scientific management, operational manuals will be prepared for the core functions of the company.

#### **3.4. Organization and Management**

The project will be managed by qualified professionals given the vast experience that the promoters have acquired over years in running and managing similar businesses. The Board of Directors formulates policy and offer strategic business guidance to management and regularly monitor and evaluate performance of the company.

All the production line will be under the administrator under which the day to day leader/management of production line will be vested in the management team headed by a Administrator. The Administrator is to be assisted by qualified and experienced personnel.

Table 3.1. Proposed organization and manpower requirement for the plant is as follows:

S/No.	DEPARTMENT	STRENGTH /NUMBERS	MONTHLY SALARY US\$	ANNUAL BUDGET US\$
A	<b>ADMINISTRATION AND FINANCE</b>			
	HR Coordinator	1	782.61	9,391.30
	Office Administrator	1	782.61	9,391.30
	Drivers	5	434.78	26,086.96
	Marketing officer	5	391.30	23,478.26
	<b>SUB TOTAL</b>	<b>12</b>	<b>2,391.30</b>	<b>68,347.83</b>
B	<b>MANAGEMENT</b>			
	Chief Financial Officer	1	2,174.00	26,088.00
	HSE Manager	2	1,086.96	26,086.96
	Project manager	2	1,173.91	28,173.91
	Store Manager	2	869.57	20,869.57
	Accountant	5	652.17	39,130.43
	asst. Accountant	15	521.74	93,913.04
	Drivers	2	330.43	7,930.43
	<b>SUB TOTAL</b>	<b>29</b>	<b>6,808.78</b>	<b>242,192.35</b>
C	<b>MAINTAINANCE</b>			
	Mechanics	2	913.00	21,912.00
	Electrician	2	913.00	21,912.00
	Chemical Processing engineer	3	870.00	31,320.00
	Civil engineer	2	1,000.00	24,000.00
	Plumbing	3	1,087.00	39,132.00
	Laboratory Technician	3	783.00	28,188.00
	Maintenance Planners	3	761.00	27,396.00
	Drivers	5	326.09	19,565.22
	Senior ICT	2	1,348.00	32,352.00
<b>SUB TOTAL</b>	<b>25</b>	<b>8,001.09</b>	<b>245,777.22</b>	
D	<b>OPERATION</b>			
	Supervisors	5	1,043.00	62,580.00
	Production Engineers	4	1,043.48	50,086.96
	Project coordinators	2	609.00	14,616.00
	HSE Coordinators	2	478.00	11,472.00
	Drivers	150	696.00	1,252,800.00
	Training Coordinator	3	783.00	28,188.00

	Quality controller	5	1,174.00	70,440.00
	Tank filling personals	6	1,174.00	84,528.00
	Utility worker	12	522.00	75,168.00
	<b>SUB TOTAL</b>	<b>189</b>	<b>7,522.48</b>	<b>1,649,878.96</b>
	<b>STORE AND LOGISTIC</b>			
E	Logistic Liaison	2	957.00	22,968.00
	Purchasing Coordinator	2	1,087.00	26,088.00
	Store supervisor	3	652.00	23,472.00
	Store person	11	522.00	68,904.00
	Drivers	5	330.43	19,826.09
	<b>SUB TOTAL</b>	<b>23</b>	<b>3,218.00</b>	<b>141,432.00</b>
	<b>GRAND TOTAL</b>	<b>278</b>	<b>27,941.65</b>	<b>2,347,628.35</b>

## 4.0. PROJECT FINANCING AND CAPITAL INVESTMENT SUMMARY

### 4.1. Project Cost & Financing Pattern

The proposed integrated project is estimated to cost a total of US\$ 50,450,493.70 this including, own equity of 100% US\$ 50,450,493.70 as proceeds from capital contribution of the project. The Current asset of US\$ 5,563,975 during the first year of operation and it increase as the project will be in full operation (see income statement), fixed assets 50,102,668US\$ and total liquidity of 116,956,165US\$. The project will be implemented within 5 years.

### 4.2. Project Capital Investment Summary

Boo	Investment Summary	
	<b>land and Buildings</b>	
1	land and Buildings	21,739.13
2	Buildings (administration block)	8,695.65
3	Laboratory	15,217.39
4	Store for chemical, spare parts, etc	23,218.00
5	Camp and workshop	7,826.09
	<b>Sub total Fixed Assets</b>	<b>76,696.26</b>
6	<b>Machineries and Equipment's</b>	
7	3750MT X 4 NOS Mounded Bullet complete	18,856,341.00
8	SA Class 2 of Steel for LPG Mounded Tanks to store 3750MT of LPG storage Tank	8,372,000.00
9	Generators (2)	402,500.00
10	other Accessories	156,000.00
	<b>Subtotal Fixed Assets</b>	<b>27,786,841.00</b>
	<b>Motor vehicles</b>	
11	Heavy Truck LPG 100	20,000,000.00
12	Light Truck for Distribution 50	2,000,000.00
13	Light Vehicles 5	100,000.00
	<b>Subtotal Fixed Assets</b>	<b>22,100,000.00</b>
	<b>Other Facilities</b>	
14	Furniture and fittings	32,608.70
15	Office Equipment's	41,304.35
16	Other cost	65,217.39
	<b>Sub total Fixed Assets</b>	<b>139,130.43</b>
	<b>Sub total Fixed Assets</b>	<b>50,102,667.70</b>
	<b>Current Asset</b>	
17	Pre operational expenses	130,434.78
18	Working capital	217,391.30

	Sub total current Assets	347,826.09
	<b>Total Investment</b>	<b>50,450,493.78</b>
	<b>Equity + Loan</b>	
1	<b>Loan (0%)</b>	-
2	<b>equity (100)</b>	<b>50,450,493.78</b>
	<b>Total Equity</b>	<b>50,450,493.78</b>

## 5.0. RISK ANALYSIS

### 5.1. Risk Analysis

Risk is the probability that an event or action will adversely affect the organization. Risk assessment is the identification and analysis of risks associated with the achievement of operations, financial reporting and compliance goals and objectives. Risk management is a central part of the OILCOM (T) LIMITED. The Industry's management will determine the level of operations, financial and compliance risk they are willing to assume. Risk assessment is one of the Company's management responsibilities.

### 5.2. Macroeconomic risk analysis

Since early 1986, the government of Tanzania has launched a comprehensive economic policy and stabilization plan with the aim to enhance the amount of infrastructure construction and improve the lives of the poor. During this time the main economic indicators significantly improved. However, uneven development of various region in the country, lack of relevant infrastructure in transportation, telecommunications, networking, health facilities, electricity and water supplies have proven to be investment barriers. Overall, Tanzania has a weak economic foundation but the project can achieve a greater impact in attaining social and economic goals for the country.

### 5.3. Finance risk analysis

- a) **Supply Risk:** The risk in Primary production relates to supply of raw material, transportation and price fluctuations. There is no assurance of enough supply of raw materials in the local market instead mostly of raw materials are imported.
- b) **Processing Risks:** The technology, machines and equipment used in Gas processing are in rudimentary stages all of which contribute to reducing production efficiency. Also quality/food safety and standards consideration in the production environment is limited. In gold processing facilities operation know-how is very low as there are notarized labourers.
- c) **Sales/market risk:** Placing value added products on the consumer markets bears risk of demand fluctuations and rejections through retailers. Furthermore, distributor are not aware of the selling price mostly are controlled by world market.

### 5.4. Other potential external risk

- a) **Lack of Governance:** the governance mechanism in the value chain is underdeveloped, actors operate in an uncoordinated and unorganized fashion, and if rules exist they are often ignored;
- b) **Lack of market coordination:** No lead organization has a coordinating role in relation to markets, technology and information such that producers and processors have no incentives for improving neither their product nor the chain process to promote sustainable income earning opportunities;

- c) **Unclear and conflicting roles regulatory authorities:** Regulatory Agencies are responsible for quality control as well as enforcing TBS, NEMC etc, are regulatory role in issuing licensing in Tanzania
- d) **Industry associations:** Associations are weak at all levels of the chain;
- e) **Operating procedures:** Standard procedures are inadequately enforced, or not enforced at all, because of relaxed production and trade regulations; and
- f) **Integration:** there is little vertical integration of importers, mid chain actors and processors.

#### **5.4. Mitigating potential risk**

The development of a large and complex project such as OILCOM (T) LIMITED is necessarily accompanied by multiple risks during all the phases of the project development, construction, operation and maintenance. The right approach to manage the project in a manner which is fairly and adequately address the multiple risks in a comprehensive as well as systematic manner is to use the risk analysis and management methodology which identifies the risk issues and their instrumental cause. In this regard, the risk is eliminated or effectively managed by the party best suited with capacity to handle or deal with the risk factors.

## 6.0. ECONOMIC AND SOCIAL ASPECTS

The project is also likely to have a positive impact on the economy of Lake Zone regions and Tanzania as a whole by creating employment, and contributing to Government revenues through various taxes, which will be paid. It also has potential for substantial exporting to foreign markets especially to neighboring countries in the Great Lakes Region. In summary the following table will show impact investment index framework

### 6.1. Impact Investment Index Framework

<b>Impact Investment Index</b>		
<b>Frame Work for OILCOM (T) LIMITED</b>		
<b>Performance Area</b>	<b>Quantitative Indicator</b>	<b>Remarks</b>
<b>Investment Capital</b>	Total investment capital, CAPEX and OPEX US\$ 50,450,493.78US\$	Substantial amount of capital invested into the domestic economy.
<b>Export Earnings</b>	Indicative Annual sales of earnings of 113,478,260.87US\$ out of annual average collection	Increased foreign earnings.
<b>Job requirements</b>	Job creation after plant in operation 2022-2027. DIRECT TANZANIAN JOBS 278 local employed workers	<ul style="list-style-type: none"> <li>• Reasonable number of direct job created to local Tanzanians with direct impact on poverty reduction through enhanced income generation; and</li> <li>• Improving skills development for Industrial production</li> </ul>
<b>Technology applied</b>	High Tech Environmentally friendly machinery	<ul style="list-style-type: none"> <li>• Enhancing technological transfer; and</li> <li>• Applied technology which is free from environmental pollution,</li> </ul>
<b>Other Implied Project Benefits</b>		
<ul style="list-style-type: none"> <li>▪ Increased sales to the Utility Companies providing services of electricity, water and sewerage, telecommunications;</li> <li>▪ Increased business transacted by local banks and institutions providing financial services;</li> <li>▪ Business opportunities for local entrepreneurs in market distribution channels,</li> <li>▪ Business opportunities to contractors and sub-contractors during the minor construction phase;</li> <li>▪ Increased regional intra-trade and international trade due to better infrastructure facility and links to markets;</li> <li>▪ Increase of technology transfer &amp; expertise to local employed staff,</li> <li>▪ Capital spends in local economy over 50.45Million US\$ Millions and</li> <li>▪ Contribution to GDP growth through increased economic activities</li> </ul>		

Based on the Impact Investment Index analysis, the company can develop projections that the project can deliver both value for money in the context of broad socioeconomic impact and return on investment while complying with governance requirements. In this regard therefore, OILCOM (T) LIMITED will promote the industrialization process in the country, create employment, attract new technologies, expand foreign exchange earnings and ultimately contribute substantially to the country's economic growth.

## 7.0. FINANCIAL MODELLING AND ANALYSIS

The Financial Modelling and analysis, is the main source of information for assessing the potential financial viability of the OILCOM (T) LIMITED. The analysis is based on the assumptions that have been taken for the implementation of the site development, demand and the associated potential investment requirements for a 5 year time period. The purpose of establishing this project is to speed up the country's economic development by being a catalyst for restructuring the existing local industrial set up and attracting new, both foreign and domestic entrepreneurs to a liberalized legal business framework.

### 7.1. Project investment inputs and revenue projects

Machine No.	Size	Cylinder /Truck Size	Cylinder /Truck Size	Felling capacity	Filling Capacity per Month
Filling Carousel 1	24 post	6Kg	6Kg	450,000	2,700.00
Filling Carousel 1	12 Post	6Kg	6Kg	200,000	1,200.00
Filling Carousel 1	12 Post	15Kg	15Kg	100,000	1,500.00
Stand Alones	5 post	38Kg	38Kg	15,000	570.00
Bulk Truck Loading	8 bays	20MT	20MT	64	1,280.00
<b>Total</b>				<b>765,064</b>	<b>7,250.00</b>
Price per Kg in US\$					1.304
Price per MT in US\$					1,304.35
Monthly expected sales					9,456,521.74
Yearly expected sales of Gas					113,478,260.87

### 7.2. Production, Revenue and project viability

- ✚ The estimated revenue gain in provision of gas annually 113,479,260.87US\$ in the first year of production per 87,000MT of Gas produced in the first year and increases positively.
- ✚ Net profit before tax is 9,087,194US\$, second year earning is ten times to 12,673,286US\$, which show the profit is increasing, (see Income statement)
- ✚ Net profit after tax for the first years in production is 5,563,975US\$ and second year is increasing to 7,759,694US\$ for remaining year increasing positively, (see Income statement). But this first year of production the company had negative provision to shareholders (see balance sheet)

- ✦ Gross sales contribution in the first year of service is quietly promising (see Income statement )
- ✦ The expected sales increase in a second year over 5%, this is due to the company will utilize all necessary machine and equipment during the operation of the project after imposed
- ✦ Total investment cost of the project is 50,450,493.75US\$ whereas the own equity is 100% and loan-able amount 0US\$ (see investment summary)
- ✦ The end balance of project in cash flow statement is positive and increases tremendous.(see cash flow statement)
- ✦ Testing the project viability is positive whereas IRR is positive 9.81% which is above bank assumed loan interest of 8%, and payback period of project is within 4 to 5 years. Which is project economic life
- ✦ Return on investment is posit positive and increases tremendously (see balance sheet)
- ✦ Breakeven point is positive from the first year of operation.

### **7.3. Objective and Scope of Financial Model**

#### **7.3.1. Objective**

The main objective of the financial modelling and analysis is to setup a financial model framework for potential generated revenues and operational & maintenance costs for the full operation of OILCOM (T) LIMITED based on the assumptions taken for the Market Analysis, the plan for the facility development, unit production costs and other overhead and operational charges.

#### **7.3.2. Scope**

The scope consists of a financial model that will be used to analyse the potential financial viability of the project based on the assumptions taken for the concept and scope of the project on the Market Analysis. The financial model has been developed in excel spread sheet and include information on costs, expenses and the subsequent sales revenue based on the average market prices and linked to the financial cash flow.

#### **7.3.3. Project financial plan.**

The project financial plan primarily consists of income statement, cash flow projection and balance sheet. From these 3 financial statements the project will derive Break even points, internal rate of returns, loan payment schedules, payback period and other financial ratios. These reports constitute reasonable estimate of company financial future. More importantly, the process of thinking through the financial plan improves insight into inner financial working of company.

## ANNEX I – INCOME STATEMENT

<u>Revenue</u>	<u>0</u>	<u>Year 1</u>	<u>Year 2</u>	<u>Year 3</u>	<u>Year 4</u>	<u>Year 5</u>	<u>TOTAL</u>
Yearly expected sales of Gas		113,478,261	119,152,174	125,109,783	137,620,761	151,382,837	646,743,815
<b>Total Operating Revenue</b>	-	<b>113,478,261</b>	<b>119,152,174</b>	<b>125,109,783</b>	<b>137,620,761</b>	<b>151,382,837</b>	<b>646,743,815</b>
<u>Expenses</u>	<u>0</u>	<u>Year 1</u>	<u>Year 2</u>	<u>Year 3</u>	<u>Year 4</u>	<u>Year 5</u>	<u>Total</u>
Salaries		2,347,628	2,394,581	2,873,497	3,448,197	4,137,836	15,201,739
Social Charges & Pension Payments		469,526	478,916	574,699	689,639	827,567	3,040,348
Purchase of Raw materials/Unprocessed Gas		73,913,043	75,391,304	76,899,130	78,437,113	80,005,855	384,646,447
Fuel		19,956,522	20,355,652	20,762,765	21,178,021	21,601,581	103,854,541
Lubricants		782,609	798,261	814,226	830,511	847,121	4,072,727
Tires and tubes		1,878,261	1,915,826	1,954,143	1,993,225	2,033,090	9,774,545
Repair and Maintenance		1,173,913	1,197,391	1,221,339	1,245,766	1,270,681	6,109,091
Insurance/licensing/other charges		391,304	399,130	407,113	415,255	423,560	2,036,364
Other Costs		3,478,261	3,547,826	3,618,783	3,691,158	3,764,981	18,101,009
<b>Total Operating Costs</b>		<b>104,391,067</b>	<b>106,478,888</b>	<b>109,125,696</b>	<b>111,928,885</b>	<b>114,912,273</b>	<b>546,836,809</b>
<b>Operational Net Earnings before Depreciation, Interest &amp; Tax</b>		<b>9,087,194</b>	<b>12,673,286</b>	<b>15,984,087</b>	<b>25,691,876</b>	<b>36,470,564</b>	<b>99,907,006</b>
<i>%age Gross Contribution</i>		<i>8</i>	<i>11</i>	<i>13</i>	<i>19</i>	<i>24</i>	<i>1</i>
Depreciation at 5 -12.5 % (mostly civil works)		795,129	1,108,912	1,398,608	2,248,039	3,191,174	8,991,631
Net Earnings before Tax & Interest		8,292,064	11,564,373	14,585,479	23,443,837	33,279,390	90,915,376
Interest Paid (Bank Loan)		-	-	-	-	-	-
Tax (30%)		2,728,089	3,804,679	4,798,623	7,713,022	10,948,919	29,993,332
<b>Net Earnings</b>		<b>5,563,975</b>	<b>7,759,694</b>	<b>9,786,857</b>	<b>15,730,814</b>	<b>22,330,470</b>	<b>61,171,811</b>

## ANNEX II – CASH FLOW

Cash Flow statement from Investing Activities for 5 years					
(all numbers in US\$)	Year 1	Year 2	Year 3	Year 4	Year 5
<b><u>CASH FLOW FROM OPERATING ACTIVITIES</u></b>					
Cash receipts from Sales	113,478,261	119,152,174	125,109,783	137,620,761	151,382,837
Cash paid to suppliers and employees	3,478,261	3,547,826	3,618,783	3,691,158	3,764,981
Cash generated from operations	116,956,522	122,700,000	128,728,565	141,311,919	155,147,818
Dividends received*	0	0	0	0	0
Interest received	0	0	0	0	0
Interest paid	0	0	0	0	0
Tax paid	(2,728,089)	(3,804,679)	(4,798,623)	(7,713,022)	(10,948,919)
<b>Net cash flow from operating activities</b>	<b>114,228,433</b>	<b>118,895,321</b>	<b>123,929,943</b>	<b>133,598,897</b>	<b>144,198,899</b>
<b><u>CASH FLOW FROM INVESTING ACTIVITIES</u></b>					
Replacement of equipment	0	0	0	0	0
Proceeds** from sale of equipment	0	0	0	0	0
<b>Net cash flow from investing activities</b>	<b>0</b>	<b>0</b>	<b>0</b>	<b>0</b>	<b>0</b>
<b><u>CASH FLOW FROM FINANCING ACTIVITIES</u></b>					
Proceeds from capital contributed	0	0	0	0	0
Proceeds from loan	0	0	0	0	0
Payment of loan	0	0	0	0	0
<b>Net cash flow from financing activities</b>	<b>0</b>	<b>0</b>	<b>0</b>	<b>0</b>	<b>0</b>
<b><u>NET INCREASE/ DECREASE IN CASH</u></b>	<b>114,228,433</b>	<b>118,895,321</b>	<b>123,929,943</b>	<b>133,598,897</b>	<b>144,198,899</b>
Cash at the beginning of the period	5,563,975	7,759,694	9,786,857	15,730,814	22,330,470
Cash at the end of the period	<b>119,792,408</b>	<b>126,655,016</b>	<b>133,716,799</b>	<b>149,329,711</b>	<b>166,529,370</b>

## ANNEX III – BALANCE SHEET

Pro forma balance sheet					
(all numbers in US\$)	Year 1	Year 2	Year 3	Year 4	Year 5
<b>ASSET</b>					
Current asset	5,563,975	7,759,694	9,786,857	15,730,814	22,330,470
Fixed asset	50,102,668	49,307,538	47,908,931	45,660,891	42,469,717
Liquidity	116,956,522	122,700,000	128,728,565	141,311,919	155,147,818
<b>TOTAL ASSET</b>	<b>172,623,165</b>	<b>179,767,233</b>	<b>186,424,352</b>	<b>202,703,625</b>	<b>219,948,006</b>
<b>NET ASSET MINUS DEPRECIATION</b>	<b>171,828,035</b>	<b>178,658,320</b>	<b>185,025,745</b>	<b>200,455,586</b>	<b>216,756,832</b>
<b>EQUITY &amp; LIABILITIES</b>					
<b>Equity</b>	50,450,494	47,927,969	45,531,571	43,254,992	41,092,243
<b>Reserves</b>					
<b>Total Own Equity</b>	<b>50,450,494</b>	<b>47,927,969</b>	<b>45,531,571</b>	<b>43,254,992</b>	<b>41,092,243</b>
<b>Provisions</b>	117,854,323	125,816,760	133,296,944	147,239,532	161,524,496
<b>Long term loan</b>	0	0	0	0	0
<b>Short term Liabilities</b>	3,523,219	4,913,591	6,197,230	9,961,061	14,140,093
<b>Total Equity &amp; Liabilities</b>	<b>171,828,035</b>	<b>178,658,320</b>	<b>185,025,745</b>	<b>200,455,586</b>	<b>216,756,832</b>
<b>NET FA/CL</b>	0.29	0.27	0.26	0.23	0.19
<b>CL/CA</b>	0.63	0.63	0.63	0.63	0.63
<b>DEBIT/CAPITAL RATIOS</b>	0.71	0.73	0.75	0.78	0.81
<b>ROI</b>	11.0	16.2	21.5	36.4	54.3
<b>BREAK EVEN POINT</b>	5.51	3.89	3.00	1.78	1.16
<b>BREAK EVEN RATIO</b>	11.88	8.79	7.21	4.74	3.54
<b>EQUITY/TOTAL LIABILITIES</b>	29	27	25	22	19

## ANNEX IV - IRR

### IRR for the Project

(all numbers in US\$)

	Initial Investment	-50,450,494
Year 1	Additional Annual Net Profit	5,563,975
Year 2	Additional Annual Net Profit	7,759,694
Year 3	Additional Annual Net Profit	9,786,857
Year 4	Additional Annual Net Profit	15,730,814
Year 5	Additional Annual Net Profit	22,330,470
	<b>IRR (in 5 years)</b>	<b>9.81%</b>

The IRR above indicates that the expected return on theus \$ 50,450,494 initial investment after 5 years is 9.81%.

## ANNEX V PAY BACK PERIOD

### Payback Period Analysis

	Year	Beginning Balance	Net Cash Flows	Ending Balance
Cost of investment	0.00	50,450,493.78	0.00	50,450,493.78
	1.00	50,450,493.78	5,563,975.18	44,886,518.60
	2.00	44,886,518.60	7,759,694.30	37,126,824.30
	3.00	37,126,824.30	9,786,856.65	27,339,967.66
	4.00	27,339,967.66	15,730,814.49	11,609,153.17
	5.00	11,609,153.17	22,330,470.38	10,721,317.21

<b>Payback Period =</b>	<b>5</b>	<b>Years</b>
-------------------------	----------	--------------

## **8.0. CONCLUDING REMARKS AND WAY FORWARD**

### **8.1. Evidence of project viability based on financial model and policy Framework support**

On the basis of all the analysis done on this Business Plan on all aspects of assessment on both SWOC Analysis, market analysis, risk analysis and the financial analysis, the proposed investment options in the project as prescribed on this business plan have shown that the project is commercially viable. Nonetheless, OILCOM (T) LIMITED through professional consultative manner, will continue to find ways of implementing cost effective options given time and financial resources that will be made available. Financial analysis results show that when the construction of plant facility is financed using a combination of equity debt ratio (100:0), it gives an IRR of about 9.81%. The computed IRR is well above Dollar market of the annual loan interest rate of (8.00%) which is technically interpreted that the project is financially viable. The payback period for the project is estimated at 4 to 5 years, which is within the range for this type of investment. Sensitivity analysis results also favor the project. Financial analysis for the project has shown feasible returns. Based on the investment scope and the assumptions taken in this Business Plan, the project will not face any difficulties during establishment, according to the projected cash flow be in a position to accomplish repayment of the loan and start generating profit.

### **8.2. Policy Framework Support**

The development of the OILCOM (T) LIMITED is designed to take advantages of the current Tanzanian market-oriented reforms. The Project will be developed and established to accelerate the industrialization process. The vision 2025 emphasizes the importance of the allocation of public funds for strategic investments and private sector financing for development investments.

The 15 years Perspective Plan (2020-2025); Prioritize private investment in the context of Public Private Partnership. The First Five Years Development Plan (2020-2025) recognizes the fundamental role of the private sector in enabling the government to allocate its fund to strategic projects to facilitate a higher level of development. MKUKUTA III (2020-2025) identifies Public Private Partnership as a means of increasing the level of stakeholder participation and of easing the financial burden on the government. It should be noted that existing public resources are clearly insufficient to meet Tanzanian's huge development needs. The increased use of private enterprises participation in development projects can help alleviate the financing gap. This approach is now applied by OILCOM (T) LIMITED to ensure development of one among the ultra-modern plant in Dar es Salaam Region. Private sector and investment have been recognized as the most significant potential source of additional funding required to facilitate development projects.

### **8.3. Conclusive Remarks and Way Forward**

The development of this project will be funded by private finances. The company acting through its various shareholders and structures will provide the initial risk capital amounting to 50.45 Million US\$. The company will fund the development of the project minor rehabilitations of factory building, business offices, bulk storage facilities and purchasing machines as stated on this business plan. Before the Company engages into the development of this project as a private enterprise, it needs to accomplish the pre development activities to make way for the development of the designated project. The company has to accomplish the following;

#### **a) Apply for TIC certificate**

The company by using this Business Plan and other required supporting documents should apply for the TIC Certificate at Tanzania investment centre Office. With this certificate, the company will be able to access tax reliefs which to a large extent will help to in reducing project costs, particularly in the purchasing of machineries and minor building of area of proposed industrial area.

#### **b) Conduct Environmental Impact Assessment.**

The company has to engage a consultant to conduct EIA in order to ensure that environmental and possibly other sustainability aspects are considered effectively in policy, plan and project development. The EIA Directive aims at introducing systematic assessment of the environmental effects of strategic land use related plans and programs. It typically applies to regional and local, development, waste and transport plans, within the country. EIA ensures that plans and programs take into consideration the environmental effects they cause.

#### **c) Minor rehabilitation to suit project Industrial requirement**

The company should engage a firm to make minor rehabilitation of existing structure that will suit project manufacturing requirements. The structure should include all vital service facilities described in this business plan. When possible, the process of design of the facility should be consultative inasmuch that it should allow and incorporate ideas from experienced professionals from the industry.

#### **d) Mobilizing Funds**

As previously discussed on the Financial Analysis of this business plan, financing mechanism for plant should be scrutinized well before commencing the project implementation. There may be several options of financing the project development but the company will find the best option. The investment team should do consultation with relevant financial institutions (Banks and non-bank Financial Institutions), both within and outside the country. This exercise should be more effective if the team works closely with central government agencies, particularly

TIC and the Ministry of Industry & Trade and Ministry of Investment.