

General Notes

1. All dimensions are in millimeters (mm) (UNO)

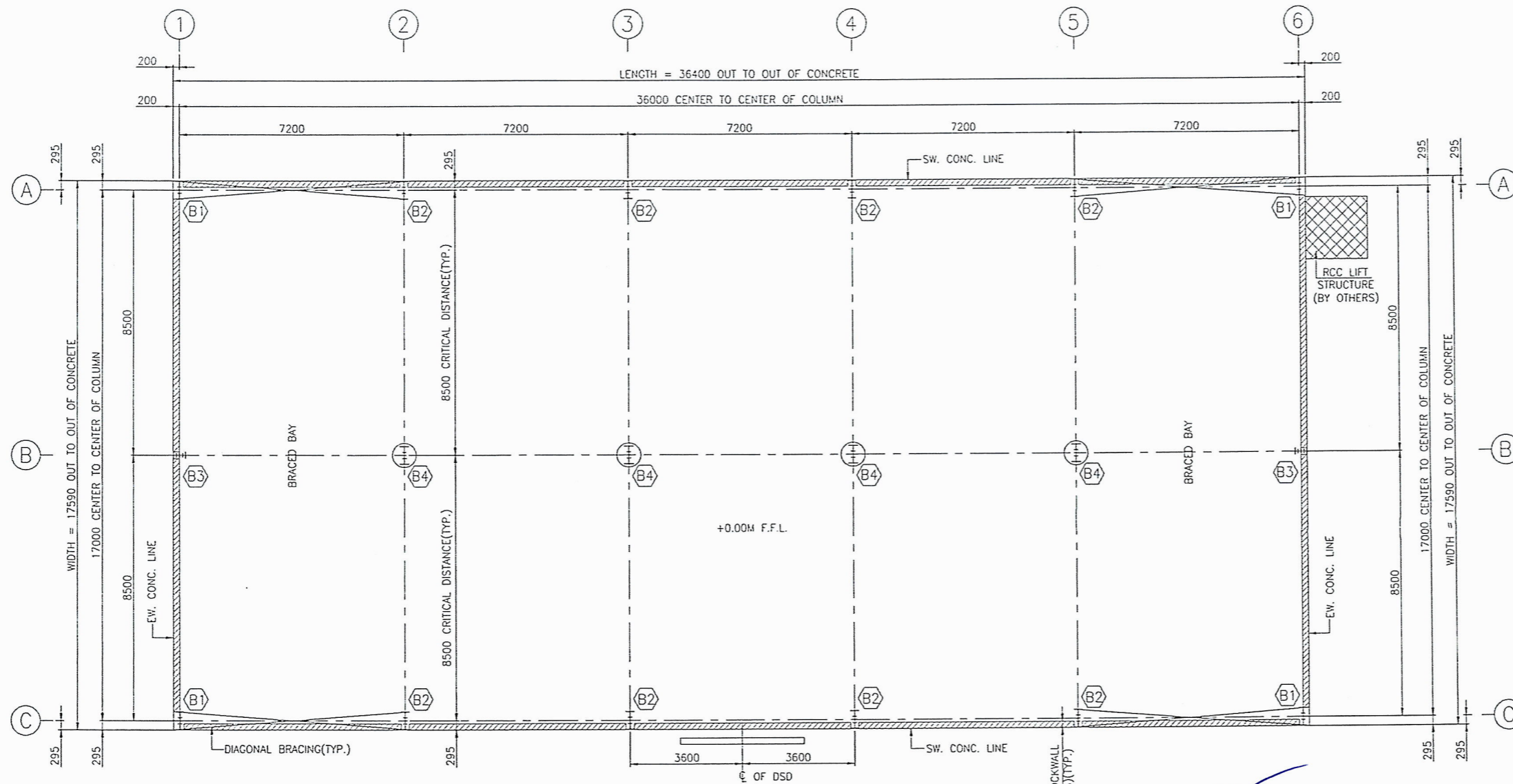

ANCHOR BOLT SETTING PLAN

DSD :- DENOTES DOUBLE SLIDING DOOR OF SIZE 4000(W)x4000(H) - 1NO.

⊕ :- DENOTES MEZZANINE COLUMNS



FOR CONSTRUCTION

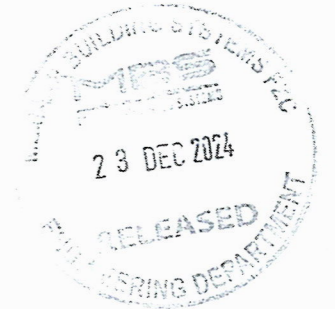

ANCHOR BOLT ASSEMBLY.

LEGEND:-
 QTY - QUANTITY
 T - THREADED BOLT PROJECTION
 E - UNTHREADED STRAIGHT LENGTH
 L - VERTICAL LENGTH
 X - HOOK LENGTH
 Lc - OVERALL LENGTH
 Wt - WEIGHT
 R - BEND RADIUS
 Lc - CENTERLINE LENGTH

NOTE:-
 EACH SUPPLIED ASSEMBLY CONSISTS OF
 1- 1" SHARPED ANCHOR BOLT
 2- HEXAGONAL NUTS AND
 1- WASHER

PART MARK	DIAMETER (D)	QTY	T (mm)	E (mm)	L (mm)	X (mm)	Lc (mm)	Wt (kg)	R (mm)	Lc (mm)
SANB051	16 mm	00	100	275	375	120	495	0.828	40	458
SANB052	20 mm	00	150	300	450	175	625	1.599	50	579
SANB053	24 mm	108	150	375	525	205	730	2.746	60	675
SANB054	30 mm	00	200	550	750	265	1015	5.778	75	946
SANB055	36 mm	00	200	850	1050	295	1345	11.112	90	1262

ANCHOR BOLT SCHEDULE

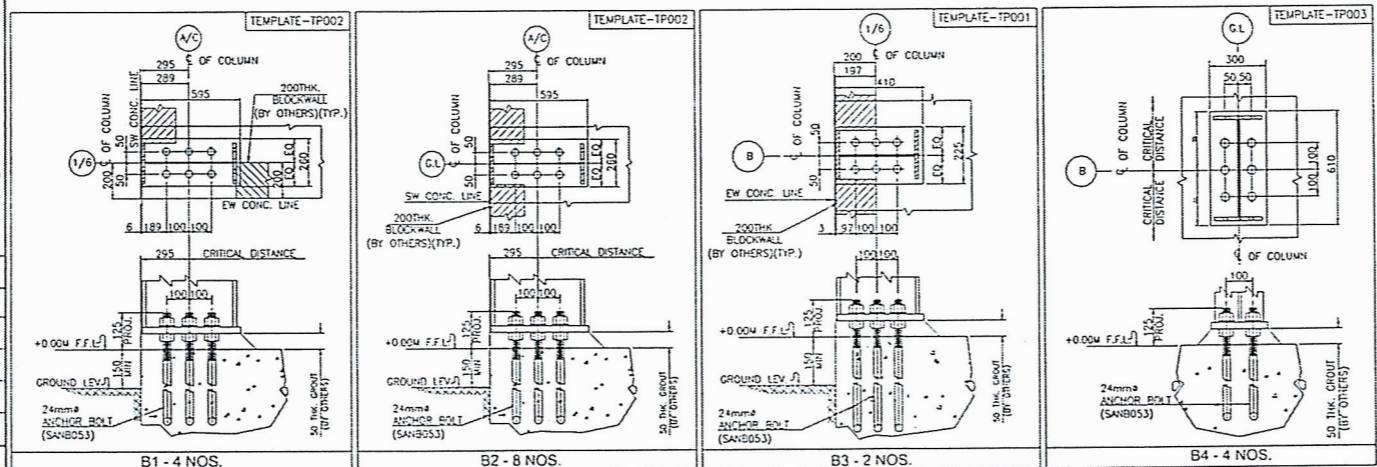

1	23 12 24	ISSUED FOR CONSTRUCTION	IRE	SKU	RKP	SAK
0	05 12 24	ISSUED FOR APPROVAL	IRE	FKP	TVG	SAK
NO.	DATE	DESCRIPTION	DSN	DRN	CHK	APD

PROJECT: Warehouse Tanzania

STEEL CONTRACTOR: MBS NEHAAR BUILDING SYSTEMS

P.O. Box 41668
 HFZ - Sharjah - U.A.E.
 E-mail : sales@mbs.ae
 Website : www.mbs.ae
 Head Office & Plant
 Phone : 009716 514 9599
 Fax : 009716 514 9593

JOB NUMBER	BUILDING NO	DRAWING NO
12.7689	B01	F01
DRAWING TITLE		FILE NO
ANCHOR BOLT SETTING PLAN & DETAILS		785301F01

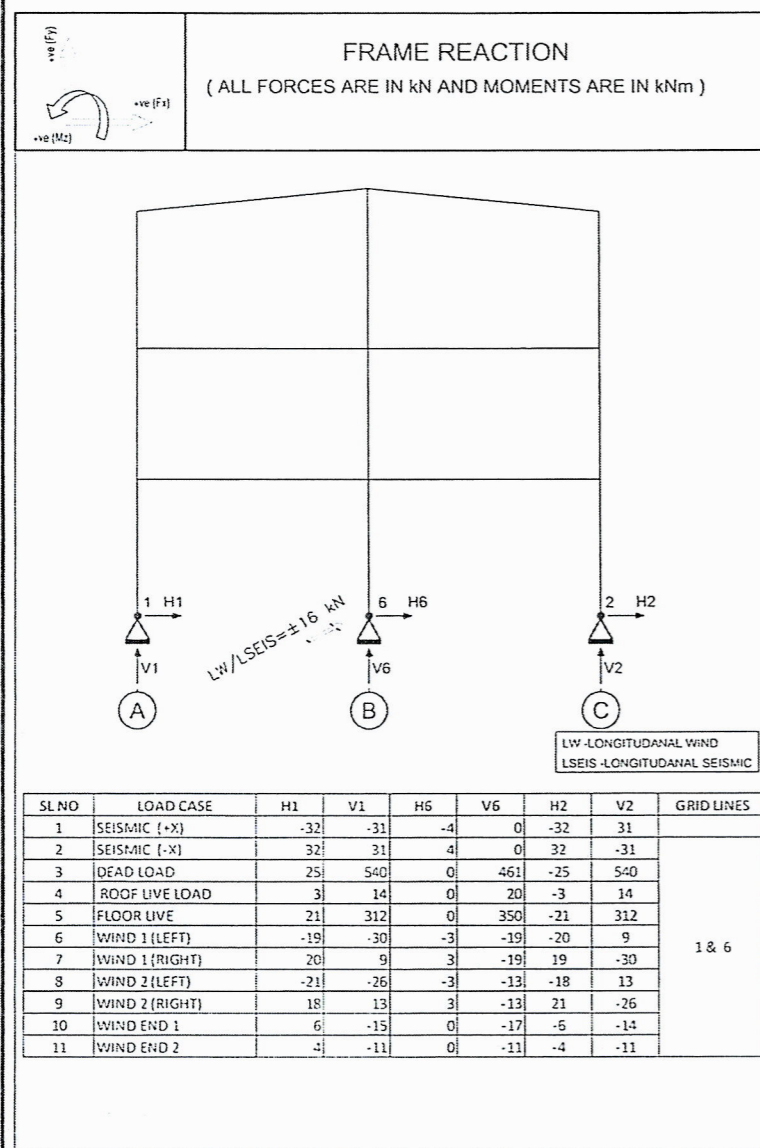
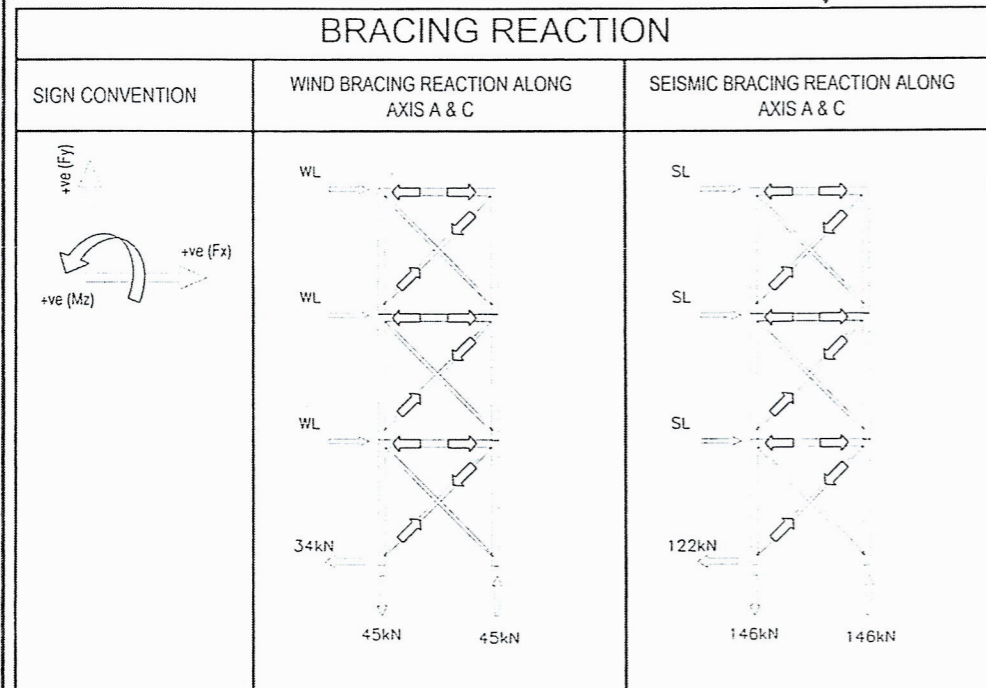

This frame is designed for half bay loading only with EW column as a part of main frame
 Dead loads includes mezzanine dead loads
 Foundations shall be designed for the given reactions as a minimum.

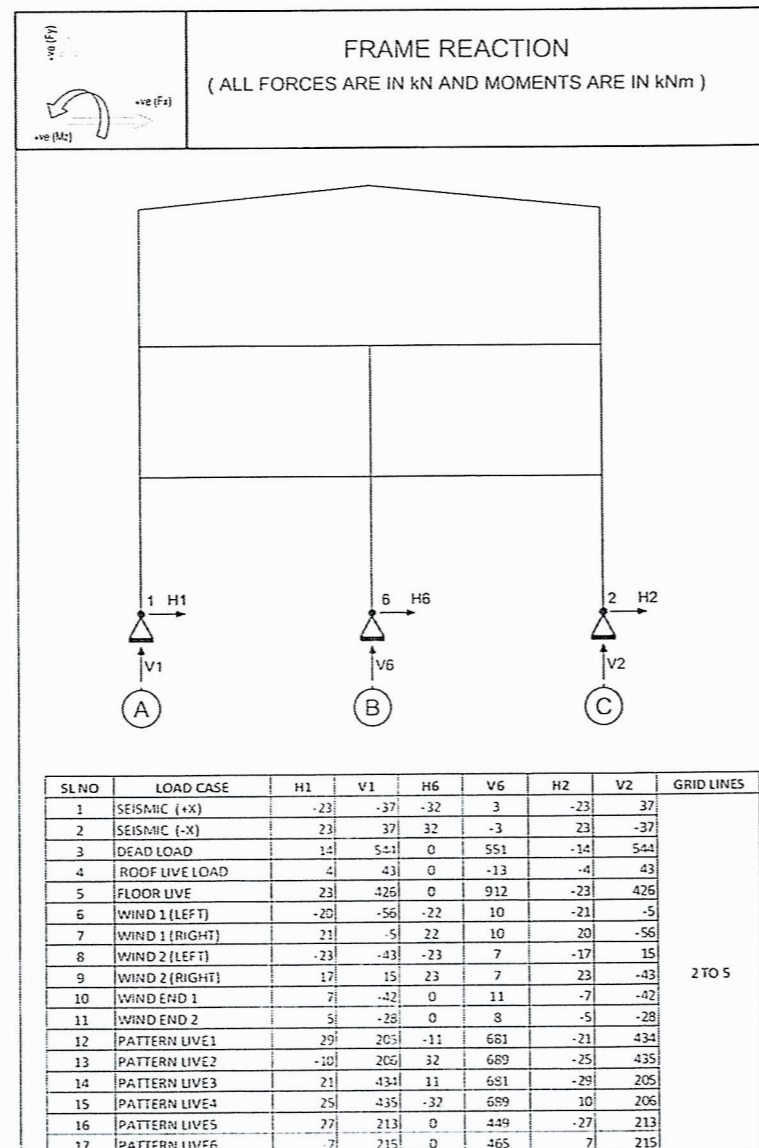

Dead loads includes mezzanine dead loads
 Foundations shall be designed for the given reactions as a minimum.

General Notes
 1. All dimensions are in millimeters (mm) (UNO)

FOR
CONSTRUCTION



NO.	DATE	DESCRIPTION	DSN	DRN	CHK	APD
1	23.12.24	ISSUED FOR CONSTRUCTION	IRE	SKU	RKP	SAK
0	09.12.24	ISSUED FOR APPROVAL	IRE	FKP	TVG	SAK

PROJECT: Warehouse Tanzania

STEEL CONTRACTOR: **MBS**
 MEHAAR BUILDING SYSTEMS
 P.O. Box 41668
 HFZ - Shaurah - U.A.E
 E-Mail : sales@mbs.ae
 Website : www.mbs.ae
 Head Office & Plant
 Phone : 009716 514 9999
 Fax : 009716 514 9933

JOB NUMBER	BUILDING NO	DRAWING NO
TZ-7883	B01	F02
DRAWING TITLE		FILE NO
REACTIONS		7885001F02