



SERENGETI
Cigarette Company
— TANZANIA —



SERENGETI CIGARETTE COMPANY (SCC)



SCC is a Tanzanian company formed in Dar es Salaam in February 2023 in order to establish the first fully integrated cigarette manufacturer in the country.

- SCC will be producing cigarettes in Tanzania for the local market and other export markets, mainly in Africa
- Primary manufacturing facility with capacity of 20,000 tons per annum

(technical details in the following slides)

- Secondary manufacturing facility initially housing 3 production lines as first stage with capacity of 10 billion sticks per annum. Already contracted with plan to be operational in Q1 2025
- The targeted capacity to install 10 Production line to reach a capacity of 30-34 Billion Stick per annum.

(technical details in the following slides)

- Shareholders with long and established track record in the tobacco industry as well as other related industrial and logistics businesses
- Supported by a principle-owned established infrastructure for sourcing (through his own company, Mkwawa Leaf tobacco Ltd, the largest tobacco buyer in Tanzania) and logistical operation: from the farmer to the factory.
- Management supported by the BMJ advisory team, bringing years of experience of management in big 4 tobacco players and other relevant expertise.

SCC Shareholders



SCC is jointly owned by Mr. Ahmed Mansoor Huwel, Mr. Ahmad Bkairat and Top trade Investment Limited.

Ahmed Huwel

- Tanzanian citizen. MBA holder from Bournemouth university. Dar es Salaam based.
- Founder of Mkwawa Leaf Tobacco Ltd (acquired the previous Universal Ltd assets); the largest tobacco buyer in Tanzania. Long history as the main transporter for tobacco suppliers in Tanzania including Universal, Premier and Alliance.
- Owner of fully integrated network of fuel & logistics: from farmers to factory
- Founder of the Tanzanian aviation company, Jambo Aviation.
- Founder, Mkwawa Pure Drinking Water.

Ahmad Bkairat

- Dominican and Jordanian citizen. Italian educated. Dubai Based.
- 35-year track record in MENA tobacco industry with major presence in the Asia, Africa and CRS
- Owner and operator of the largest private Primary facility in the MENA region (UAE based BMJ) and state of the art cigarette factory facilities (with 90 billion sticks capacity per annum) in UAE and Iraq.
- Established own-brands as well as track record in contract manufacturing for Imperial Brands Plc.
- Other industrial assets in the tobacco and consumer goods in the UAE and Iraq.



Factory located in Morogoro City.



SCC Advisory Team



SCC benefits from its relationship with the BMJ Advisory team, for the technical, production, commercial and financial expertise required from planning to the operational phase.

A large, faint, light-colored watermark of the lion and crown logo is centered in the background of the slide.

Our Objective
is to provide a high quality Cigarette for the
consumers in Tanzania and the neighboring
countries.

Tobacco & Packaging materials



Materials: Tobacco, Cigarette paper, Filters, Tipping paper Aluminium foil, Pinned packaging, Polypropylene and Cartons.

The materials sourcing.

Tobacco, our objective to use the Tanzanian Tobacco as major components, to get different Cigarette Blends, other Tobacco from different countries will be used as well, the objective is to minimize the imported Tobacco volume.

Other materials will be sourced from different countries, Europe, China, India, UAE and other.

SCC Tanzania project (Secondary)



3 KS production lines, 10 Billion sticks annual capacity And a filters line

- Three Production Lines, installation starts April 2025 Operational Q2 2025
- Plan to expand to 6 machines in 2 years after phase 1 and reaching 10 machines within 3 to 4 years
- The expansion and the formats will be determined based on markets conditions and specific customer's demand

Production lines Phase 1

MACHINE ID	OEM	TECHNOLOGY		FORMAT			SPEED (PPM)	Daily Capacity MC
		MAKER	PACKER	CIG.	OUTER	PACK FORMAT		
Soft Pack King Size	Hauni /Sasib	Nano 8	Alfa 5	KING SIZE	NAKED	Soft Pack	500	1220
Hing lid (King Size Box)	Hauni/Focke	PROTOS 90 T	FOCKE F5	KING SIZE	NAKED	REGULAR SQUARE	500	1220
Hing lid (King Size Box)	Hauni/Focke	PROTOS 90 T	FOCKE F5	KING SIZE	CARTON / NAKED	REGULAR SQUARE	500	1220
Filter Machine	Molins	FORTE/ T10 Flex	Molins	Flexible length	To Prude our own filter asper the required specification			

Cigarette Making Machinery



PROTOS 90ER/T



Technical specification – Tanzania Project

Cigarette diameter	7.80 mm
Cigarette circumference	24.50 mm
Total length of cigarette	83.00 mm
Tobacco rod length	62.0 mm
Tobacco rod weight	645 mg
Width of cigarette paper bobbin	26.50 mm
Interior dia. of cigarette paper bobbin core	120 mm + 1 mm
Exterior dia. of cigarette paper bobbin	580 mm
Filter rod diameter	7.75 mm
Filter subdivision	6-up
Length of filter	21.0 mm
Width of tipping material bobbin	26.0 mm
Interior diameter of tipping material bobbin	64.0 mm
Exterior diameter of tipping material bobbin	450 mm

Output:

10,000 cpm on King Size format / Rod speed 660 m/min.

Tray Filler & Overhead Conveyor



HCF 80 NEO



Particularly reliable tray filler for all common cigarette and filter rod Makers in the low and medium-speed sector.

Cigarette Overhead Conveyor

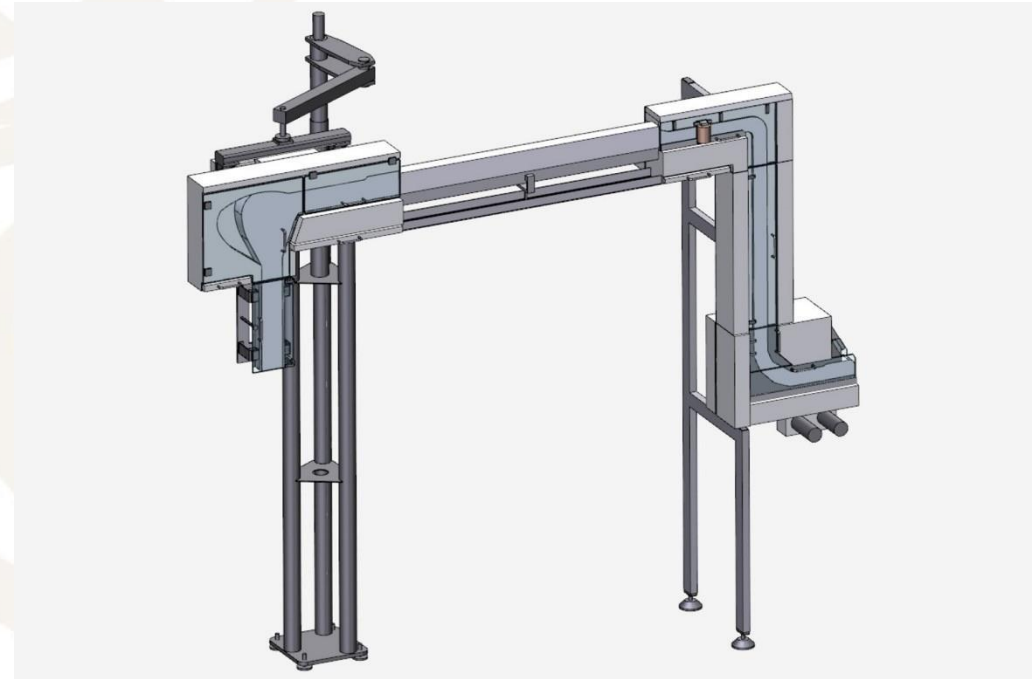

The COC (Cigarette Overhead Conveyor) is designed to link a tray filler or a cigarette maker directly with packing machinery.

Online Perforation System



Laserport 350



This online laser system is used to create ventilation zones in the filter region on finished filter cigarettes.

- Product diameter 7.80 mm
- Distance of perforation row from mouthpiece end 12.0 mm

Precise perforation ensures consistently high cigarette quality with regard to nicotine.

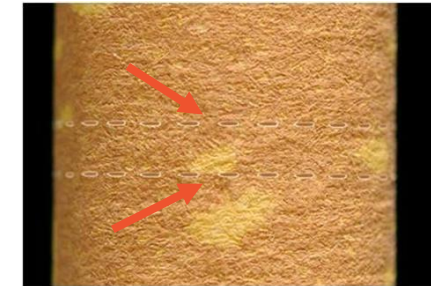

FOCKE F5 CIGARETTE PACKING MACHINERY (500PPM)



Machine Speed

500 ppm: King Size,
Queen Size,
Nano & Super Slim

Cigarettes dimensions

Length: 60 – 120 mm
Diameter: 5,4 – 8,2 mm

Pack Shapes

Regular Square
(semi-) Round Corner
(semi-) Octagonal

Specification - Tanzania Project

Focke F5 Hinge Lid Packaging Lines
in 'King Size' Format, Round Corner Pack
Shape, Line One with Boxer Over Wrapper
Model 411BOW and
Line Two with Wrapper ME Model 009



Factory Layout

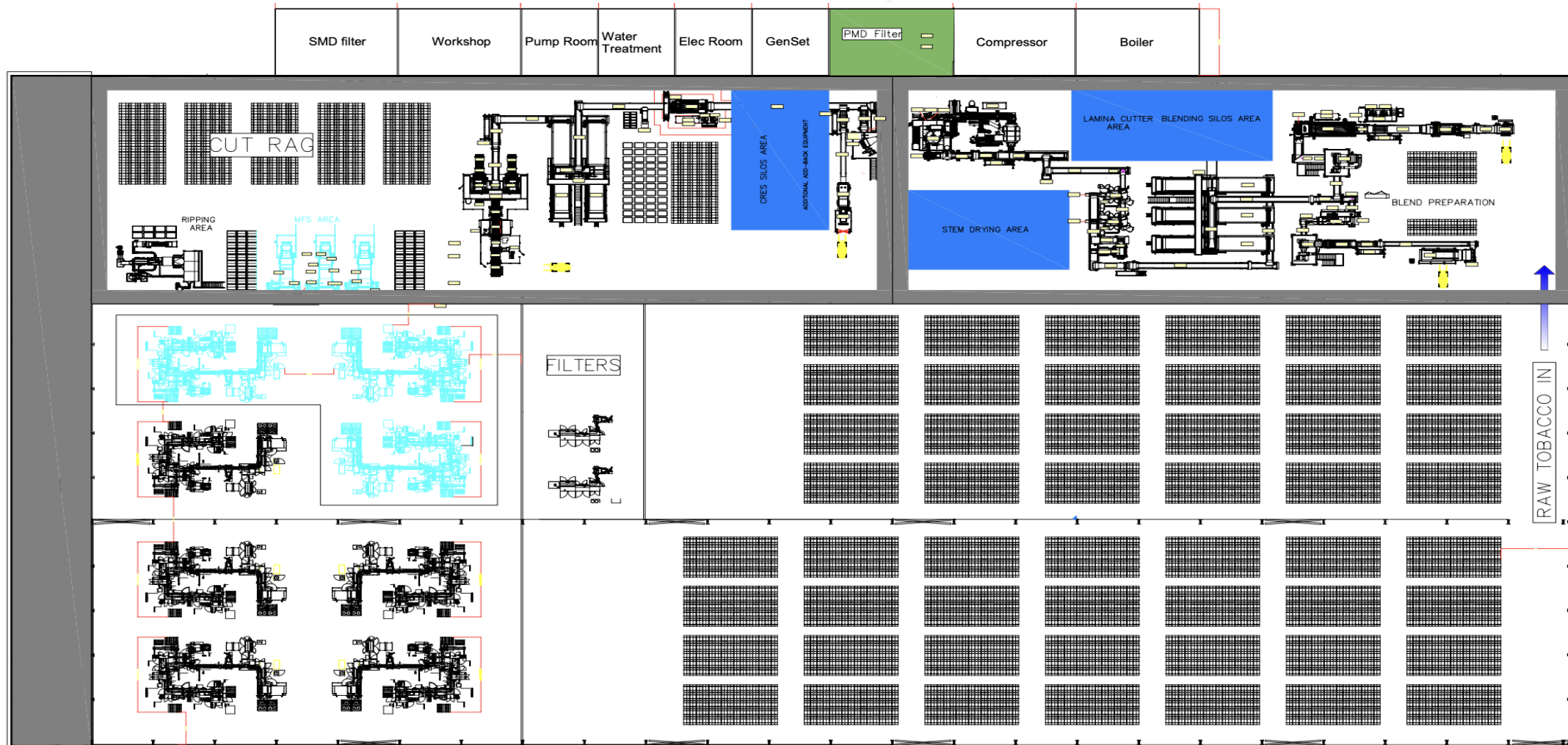

Tanzania project (Primary)



- GARBUIO Production line, 20 million KG annual capacity to be operational in Q3 2025
- Approximately 40,000 square meters of production and warehouse space (both primary and secondary)
- Tobacco sourcing from more than 14 countries in four continents (Brazil, Malawi, Zimbabwe, Tanzania, South Africa, China, India,)
- All the setup, management and reporting systems implementation will be overseen by BMJ's Advisory team as stated earlier.

Environmental, social, and governance



• Social

The focus on Social program will base on ensuring the following are attained

- ✓ Accommodation standards to worker's.
- ✓ Access to basic sanitation at home, work and accommodation
- ✓ Access to water for use and drink at home, work and accommodation

Improve Human and Labor Rights.

- ✓ Child Labor
- ✓ Forced Labor
- ✓ Human Rights Violations
- ✓ Wages of workers
- ✓ School enrolment and attendance



• Environment

Sustainable fuel use

- ✓ Reinforcing of the Community Based Forest Management to all stakeholders
- ✓ Ensuring the abiding of the Tobacco Afforestation Program

CPA use and CPA management

- ✓ Use and monitor approved CPA's
- ✓ Monitor waste management system
- ✓ Water protection

Eastern Africa Cigarette markets summary



Potential total manufactured legal cigarette market of 34 bn sticks for a RSP value of approx. \$2.5bn

Tanzania	Kenya	Uganda	DR Congo	Rwanda
5.4bn cigs - \$400mn	6.4bn cigs - \$971mn	1.8 bn cigs - \$183mn	5.8bn cigs - \$236mn	0.8bn cigs - \$32mn
JTI – 80.3% (Winston) Mastermind – 8.1% BAT – 2% PMI – 1%	BAT -82% (Sportsman) Mastermind – 16.3% PMI – 1.7%	BAT - 60% Leaf tobacco & Co - 23.2% PMI - 1.4%		
100% KS (20% KS Soft) Menthol 6.1% Virginia blend – 39% A. Blend - 61%	100% KS (50% KS Soft) Menthol 6% Virginia blend – 87.4% A. Blend - 12.6%	100% KS (67% KS Soft) Virginia blend – >70% A. Blend - <30%	Mozambique 8.1bn cigs - \$332mn	Comoro's 0.3bn cigs - \$11mn
			Burundi 1.6bn cigs - \$62mn	Malawi 2.5bn cigs - \$107mn

FROM FACTORY to CONSUMER

Distribution and Marketing.



Primary focus : Tanzanian local market

- Full distribution and marketing roadmap initiated to determine required capabilities to fast-track market entry.
- Total Retail universe estimated at 72000 outlets, serviced by 1400 wholesalers/sub-wholesalers universe.
- Consumers segmentation and brand portfolio.
- Competition capability assessment.
- Pricing & Excise strategy definition to support tier-price portfolio.

Compitons.



We are planning to produce top quality cigarettes which can compete with current market dominant International companies providing the market with multinaional brands wether its produced locally or imported.

And,

To get a good market share wuth high quality locally produced cigarette in 2-3 years time and to be the market leader, in Tanzania and the neighboring contries.

Increase the forieng Currency income to the country, due to our plan for Export.

BEYOND TANZANIA



- Free-Trade agreement for export opportunity and further distribution expansion
 - AfCFTA - African Continental Free Trade Area. Ratified in Sept 2021 by Tanzania.
 - On July 25th 2022, 7 countries (Rwanda, Cameroon, Egypt, Ghana, Kenya, Mauritius, and Tanzania) have been selected to start trading goods under AfCFTA on a pilot basis.
 - Rules of origins drives customs Tariffs. Wholly obtained products / Sufficiently worked products / Non-originated products. If non-originated products is a wholly-originated product coming from a state party and processed in another state party, it is consider wholly originated from the processing state party.
- Yemen/Tanzania FTA.
- USA (African Growth and Opportunity Act (AGOA))

Capital Investment & Working Capital



Primary and Secondary equipment:

Stage one:

Quality Control and Laboratory Instruments : \$ 5 Million

Primary \$30 Million

Secondary: \$ 25 Million

Stage Two And Three:

Adding extra 7 production Lines in 2-3 Years: \$ 60 Million

Building for Primary, secondary, Stores and Labours Dining facility facility \$ 25 Million.

Total Investment in Fixed Assets \$145 Million.

Working Capital to cover the cost of:

Tobacco, Packaging and wrapping Materials \$ 50 Million.

Working Force



At the final stage of the project:

The Group will insure a job opportunity for thousands of people as working force directly and indirectly.

Direct:

Management, Engineers, Labour at the Factory, warehouses, Sales Team and Transportation.

Indirect:

As the project is targeting to Export the product to the regional countries, this will increase the demand for raw tobacco which will encourage more farmers to join for the farming force, increase the volume of plantation and allow for more jobs in the industry.

We expect the project when reaches its final stage to add around 5000 new Job opportunity.

The foreign expert will not exceed 4-5 for maximum 2-3 years, for training Local staff, the remaining work force will be Tanzanian.

The Process



The Raw Tobacco will be processed through the Primary equipments to get the Cut Tobacco ready for Cigarette filling.

Cigarette making machine will get the Cut Tobacco and wrap it in Cigarette paper.

Packing machine, get 20 cigarette, wrap it with Aluminium Foil. Wrap them in the Box and then every 10 pack will be wrapped in one outer.

Every step, will be detected with Quality control equipment's to guarantee the product is up to the international standard.

Economic Benefits.



The cost of material and general expences fro production in the first year estimated at \$35 million.

Estimated market value \$45 million.
That make the return on investment %28.

Facility Standard



We build our Factory up to the Multi National Companies standard in:

- Primary.
- Secondary Equipment.
- Quality Controll standard.
- Warehousing.
- And other Services.

This will be an attractive for one of the big 4 in the world of Tobacco to Join in the future. Our aim is to get one of these companies as stratigic partner in the future, which will take the company to different level.



SERENGETI
Cigarette Corporation
— TANZANIA —

THANK YOU

